

# DATA SHEET

## Three Phase Induction Motor - Squirrel Cage



Customer		: ASTRAPROM			
Product line		: Multimounting IE3 Three-Phase		Product code : 13147925	
Frame	: 112M	Cooling method	: IC411 - TEFC		
Insulation class	: F	Mounting	: B5T		
Duty cycle	: S1	Rotation <sup>1</sup>	: Both (CW and CCW)		
Ambient temperature	: -20°C to +40°C	Starting method	: Direct On Line		
Altitude	: 1000 m.a.s.l.	Approx. weight <sup>3</sup>	: 44.0 kg		
Protection degree	: IP55	Moment of inertia (J)	: 0.0182 kgm <sup>2</sup>		
Design	: N				
Output [kW]	4	4	4	4	4
Poles	4	4	4	4	4
Frequency [Hz]	50	50	50	50	60
Rated voltage [V]	220/380	230/400	240/415	460	
Rated current [A]	14.6/8.47	14.3/8.20	14.0/8.09	7.28	
L. R. Amperes [A]	102/59.3	100/57.4	98.0/56.6	58.2	
LRC [A]	7.0	7.0	7.0	8.0	
No load current [A]	7.17/4.15	8.00/4.60	8.56/4.95	4.25	
Rated speed [RPM]	1445	1450	1455	1755	
Slip [%]	3.67	3.33	3.00	2.50	
Rated torque [Nm]	26.4	26.4	26.3	21.8	
Locked rotor torque [%]	200	229	260	250	
Breakdown torque [%]	270	310	340	350	
Service factor	1.00	1.00	1.00	1.25	
Temperature rise	80 K	80 K	80 K	80 K	
Locked rotor time	27s (cold) 15s (hot)	27s (cold) 15s (hot)	27s (cold) 15s (hot)	34s (cold) 19s (hot)	
Noise level <sup>2</sup>	56.0 dB(A)	56.0 dB(A)		56.0 dB(A)	
Efficiency (%)	25%	0.000	0.000	0.000	0.000
	50%	89.3	88.7	88.2	87.5
	75%	89.0	89.1	88.9	89.5
	100%	88.6	89.1	89.3	89.5
Power Factor	25%	0.00	0.00	0.00	0.00
	50%	0.65	0.60	0.57	0.58
	75%	0.76	0.72	0.70	0.70
	100%	0.81	0.79	0.77	0.77
Losses at normative operating points (speed;torque), in percentage of rated output power					
Losses (%)	P1 (0,9;1,0)	12.6	11.9	11.7	11.5
	P2 (0,5;1,0)	11.7	11.1	10.9	10.6
	P3 (0,25;1,0)	11.8	11.2	10.9	10.7
	P4 (0,9;0,5)	5.8	5.5	5.4	5.3
	P5 (0,5;0,5)	4.6	4.3	4.2	4.2
	P6 (0,5;0,25)	3.1	2.9	2.9	2.8
	P7 (0,25;0,25)	2.4	2.3	2.3	2.2
Bearing type	: Drive end 6207 ZZ	Non drive end 6206 ZZ	Foundation loads		
Sealing	: Oil Seal	Oil Seal	Max. traction	: 1388 N	
Lubrication interval	: 0 h	0 h	Max. compression	: 1820 N	
Lubricant amount	: 0 g	0 g			
Lubricant type	: Mobil Polyrex EM				
This revision replaces and cancel the previous one, which must be eliminated. (1) Looking the motor from the shaft end. (2) Measured at 1m and with tolerance of +3dB(A). (3) Approximate weight subject to changes after manufacturing process. (4) At 100% of full load.			These are average values based on tests with sinusoidal power supply, subject to the tolerances stipulated in IEC 60034-1.		
Rev.	Changes Summary		Performed	Checked	Date
Performed by					
Checked by				Page	Revision
Date	02/04/2026			1 / 3	

# DATA SHEET

## Three Phase Induction Motor - Squirrel Cage



Customer : ASTRAPROM

Notes

Rev.	Changes Summary	Performed	Checked	Date
Performed by				
Checked by			Page	Revision
Date	02/04/2026		2 / 3	

# DATA SHEET



## Three Phase Induction Motor - Squirrel Cage

Customer : ASTRAPROM

### Thermal protection

ID	Application	Type	Quantity	Sensing Temperature
1	Winding	Thermistor - 2 wires	1 x Phase	155 °C

Rev.	Changes Summary	Performed	Checked	Date
Performed by				Page 3 / 3
Checked by				
Date	02/04/2026			
				Revision

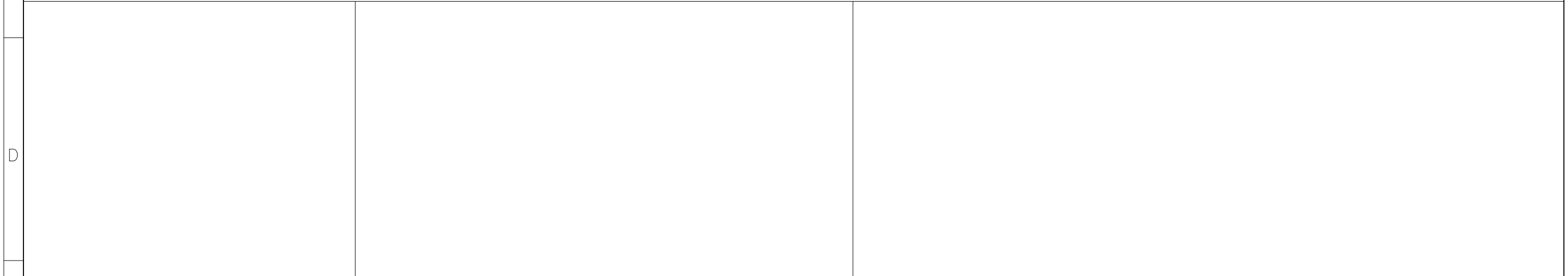
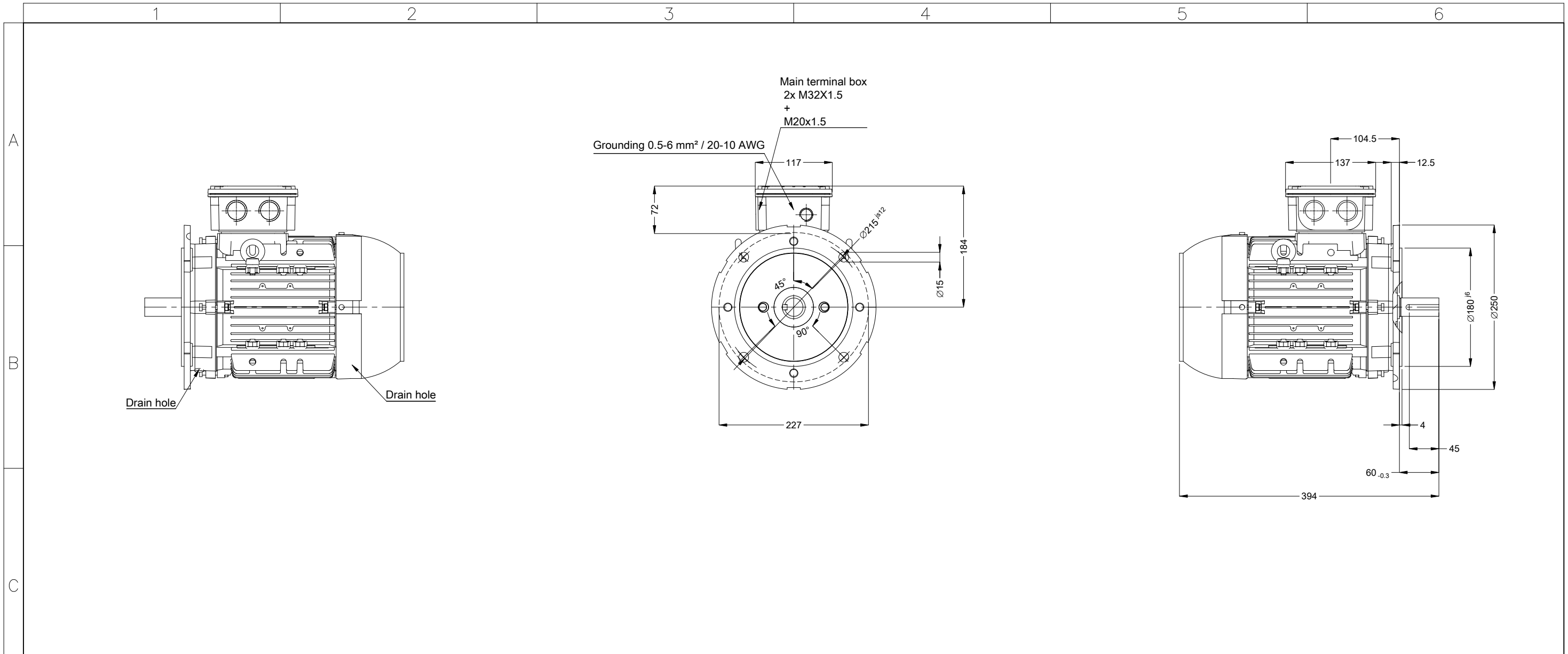

		4 kW 04 Poles 50 Hz		A	
				Scale 1 : 6	
				HYBRISUSER 00	
ECM	LOC	SUMMARY OF MODIFICATIONS		EXECUTED	CHECKED
EXECUTED	HYBRISUSER	THREE PH. MOTOR MULTIMOUNTIN TOP PREM. EFF.		RELEASED	DATE
CHECKED		FRAME 112M IP55 TEFC		VER	
RELEASED				PREVIEW	
REL. DATE				WDD	00
				SHEET 1 / 1	

- NDE sealing - lip seal
- Sealing - oil seal ring
- Bearing cap
- Thermal protection to switch off - thermistors 155°C
- Color RAL 5009
- Painting plan 207A
- Mounting B5T

