

DATA SHEET



Three Phase Induction Motor - Squirrel Cage

Customer : ASTRAPROM

Product line : Multimounting IE3 Three-Phase Product code : 13096351

Frame	: 132M	Locked rotor time	: 23s (cold) 13s (hot)
Output	: 7.5 kW (10 HP)	Temperature rise	: 80 K
Frequency	: 50 Hz	Duty cycle	: S1
Rated voltage	: 400/690 V	Ambient temperature	: -20°C to +40°C
Poles	: 4	Altitude	: 1000 m.a.s.l.
Rated current	: 14.2/8.23 A	Protection degree	: IP55
LRC	: 8.5	Cooling method	: IC411 - TEFC
Rated speed	: 1465 rpm	Mounting	: B5T
Rated torque	: 48.9 Nm	Rotation ¹	: Both (CW and CCW)
Insulation class	: F	Noise level ²	: 56.0 dB(A)
Service factor	: 1.00	Starting method	: Direct On Line
Moment of inertia (J)	: 0.0638 kgm ²	Approx. weight ³	: 70.9 kg
Design	: N		

Output	50%	75%	100%	Foundation loads	
Efficiency (%)	87.5	90.0	90.6	Max. traction	: 2876 N
Power Factor	0.67	0.78	0.84	Max. compression	: 3571 N

Losses at normative operating points (speed;torque), in percentage of rated output power

P1 (0,9;1,0)	P2 (0,5;1,0)	P3 (0,25;1,0)	P4 (0,9;0,5)	P5 (0,5;0,5)	P6 (0,5;0,25)	P7 (0,25;0,25)
10.3	9.2	8.9	4.8	3.6	2.4	1.7

		<u>Drive end</u>	<u>Non drive end</u>
Bearing type	:	6308 ZZ	6207 ZZ
Sealing	:	Oil Seal	Lip Seal
Lubrication interval	:	-	-
Lubricant amount	:	-	-
Lubricant type	:	Mobil Polyrex EM	

Notes

This revision replaces and cancel the previous one, which must be eliminated.

- (1) Looking the motor from the shaft end.
- (2) Measured at 1m and with tolerance of +3dB(A).
- (3) Approximate weight subject to changes after manufacturing process.
- (4) At 100% of full load.

These are average values based on tests with sinusoidal power supply, subject to the tolerances stipulated in IEC 60034-1.

Rev.	Changes Summary	Performed	Checked	Date
Performed by				
Checked by			Page	Revision
Date	02/04/2026		1 / 2	

DATA SHEET



Three Phase Induction Motor - Squirrel Cage

Customer : ASTRAPROM

Thermal protection

ID	Application	Type	Quantity	Sensing Temperature
1	Winding	Thermistor - 2 wires	1 x Phase	155 °C

Rev.	Changes Summary	Performed	Checked	Date
Performed by				
Checked by			Page	Revision
Date	02/04/2026		2 / 2	

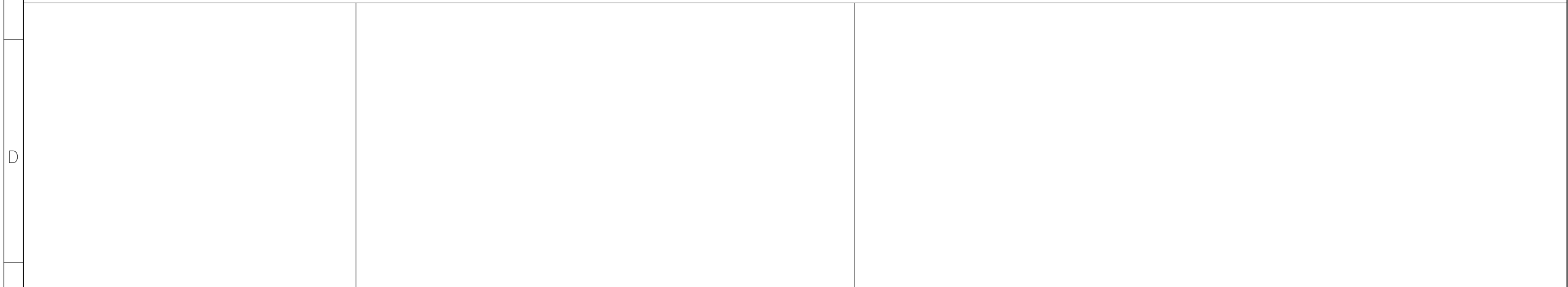
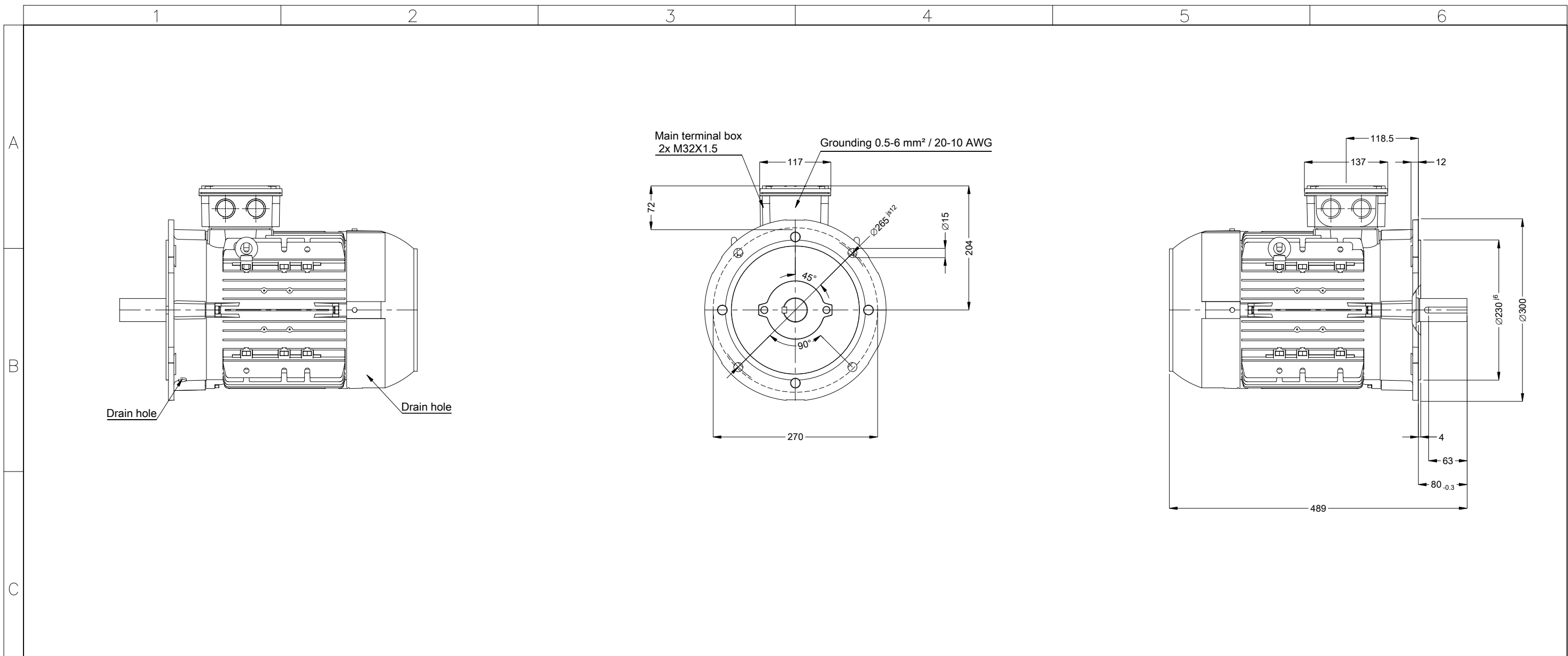

		7.5 kW 04 Poles 50 Hz		A					
				Scale 2 : 13					
				HYBRISUSER 00					
		ECM	LOC	SUMMARY OF MODIFICATIONS	EXECUTED	CHECKED	RELEASED	DATE	VER
		EXECUTED	HYBRISUSER	THREE PH. MOTOR MULTIMOUNTIN TOP PREM. EFF. FRAME 132M IP55 TEFC	PREVIEW				
		CHECKED			WDD	00			
		RELEASED			SHEET		1 / 1		
		REL. DATE							
NDE sealing - lip seal Sealing - oil seal ring Bearing cap Thermal protection to switch off - thermistors 155°C Color RAL 5009 Painting plan 207A Mounting B5T		DE Shaft End DM12 WEG WPR-7339							