

DATA SHEET



Three Phase Induction Motor - Squirrel Cage

Customer : ASTRAPROM

Product line : W22 IE3 Three-Phase Product code : 12867346

Frame	: 132M	Locked rotor time	: 36s (cold) 20s (hot)
Output	: 4 kW (5.5 HP)	Temperature rise	: 80 K
Frequency	: 50 Hz	Duty cycle	: S1
Rated voltage	: 400/690 V	Ambient temperature	: -20°C to +40°C
Poles	: 6	Altitude	: 1000 m.a.s.l.
Rated current	: 9.11/5.28 A	Protection degree	: IP55
LRC	: 6.5	Cooling method	: IC411 - TEFC
Rated speed	: 970 rpm	Mounting	: B3T
Rated torque	: 39.4 Nm	Rotation ¹	: Both (CW and CCW)
Insulation class	: F	Noise level ²	: 53.0 dB(A)
Service factor	: 1.00	Starting method	: Direct On Line
Moment of inertia (J)	: 0.0492 kgm ²	Approx. weight ³	: 76.7 kg
Design	: N		

Output	50%	75%	100%	Foundation loads	
Efficiency (%)	86.0	86.8	86.8	Max. traction	: 1491 N
Power Factor	0.53	0.66	0.73	Max. compression	: 2243 N

Losses at normative operating points (speed;torque), in percentage of rated output power

P1 (0,9;1,0)	P2 (0,5;1,0)	P3 (0,25;1,0)	P4 (0,9;0,5)	P5 (0,5;0,5)	P6 (0,5;0,25)	P7 (0,25;0,25)
14.6	13.5	13.7	7.0	5.4	3.8	3.0

	Drive end	Non drive end
Bearing type	: 6308 ZZ	: 6207 ZZ
Sealing	: V'Ring	: V'Ring
Lubrication interval	: -	: -
Lubricant amount	: -	: -
Lubricant type	: 00088	

Notes

This revision replaces and cancel the previous one, which must be eliminated.

- (1) Looking the motor from the shaft end.
- (2) Measured at 1m and with tolerance of +3dB(A).
- (3) Approximate weight subject to changes after manufacturing process.
- (4) At 100% of full load.

These are average values based on tests with sinusoidal power supply, subject to the tolerances stipulated in IEC 60034-1.

Rev.	Changes Summary	Performed	Checked	Date
Performed by				
Checked by			Page	Revision
Date	17/04/2026		1 / 2	

DATA SHEET



Three Phase Induction Motor - Squirrel Cage

Customer : ASTRAPROM

Thermal protection

ID	Application	Type	Quantity	Sensing Temperature
1	Winding	Thermistor - 2 wires	1 x Phase	155 °C

Rev.	Changes Summary	Performed	Checked	Date
Performed by				
Checked by			Page	Revision
Date	17/04/2026		2 / 2	

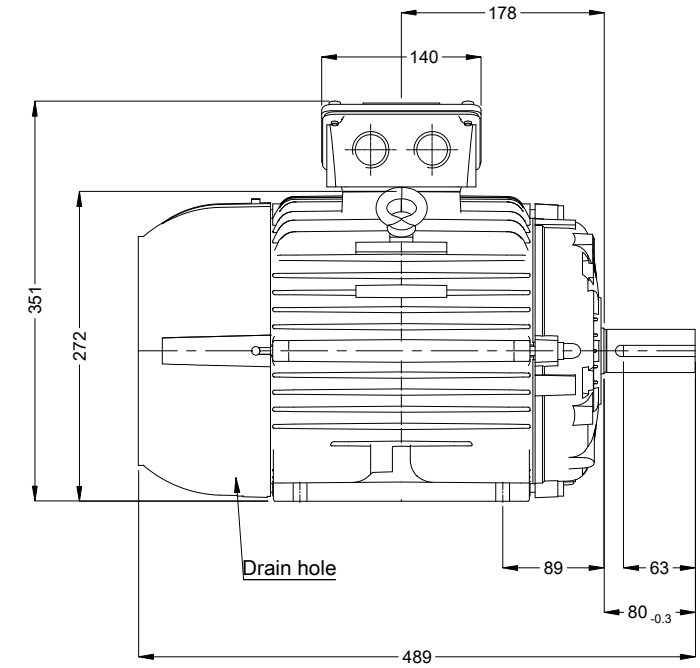
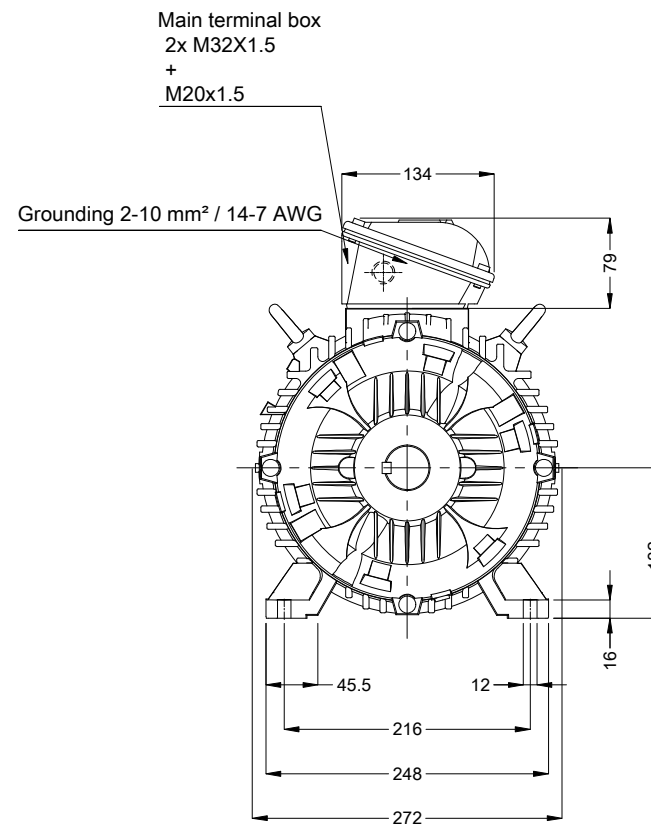
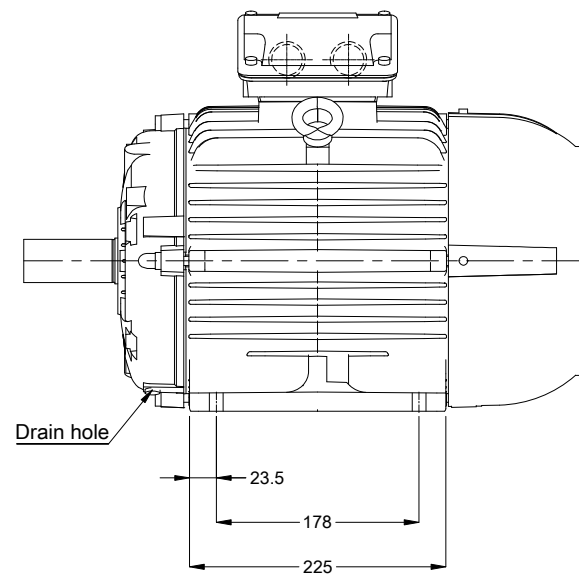

Thermal protection to switch off - thermistors 155°C
 Color RAL 5009
 Painting plan 207A
 Mounting NEMA F-3
 Mounting B3T

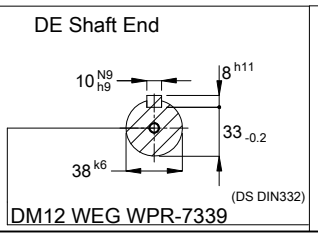

4 kW 06 Poles 50 Hz						A
Scale						2 : 13
HYBRISUSER						00
ECM	LOC	SUMMARY OF MODIFICATIONS		EXECUTED	CHECKED	RELEASED
EXECUTED	HYBRISUSER	THREE PH. MOTOR W22 IE3				
CHECKED		FRAME 132M IP55 TEFC				
RELEASED						
REL. DATE						
				PREVIEW		
				WDD	00	
				SHEET	1 / 1	