



PME50-XL-N

Flanged housing unit

Schaeffler ID:
0096438000000

Housing units PME, four-bolt flanged housing units, cast iron, centring spigot, eccentric locking collar, P seals

X-life

Technical information

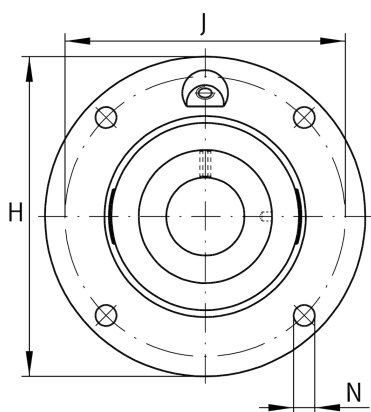

Main Dimensions & Performance Data

d	50 mm	Bore diameter
H	165 mm	Height flange
B ₁	43,8 mm	Locking collar total width
U	31,8 mm	Total height unit
C _r	37.500 N	Basic dynamic load rating, radial
C _{0r}	23.200 N	Basic static load rating, radial
C _{ur}	1.210 N	Fatigue load limit, radial
	2,13 kg	Weight

Dimensions

A	25 mm	Height housing
A ₁	13 mm	Thickness of flange
A ₂	1 mm	Distance raceway
S	3 mm	Chamfer width
Q	M8X1	Connection thread lubrication

Mounting dimensions

J	135 mm	Pitch circle diameter (holes)
N	14 mm	Fixing bore
T ₁	12 mm	Height spigot
Z	110 mm	Diameter spigot
	h8	Diameter spigot clearance
n	4	Number of screwing holes

Additional information

	1	Number of housings
	ME10	Housing
	GRAE50-XL-NPP-B	Bearing designation
	KASK10	Protecting cap