



Technical data

6021LLU5K

Single row deep groove ball bearings

Deep groove ball bearing, radial contact, pressed steel cage, contact seals on both sides

VISUAL (S)

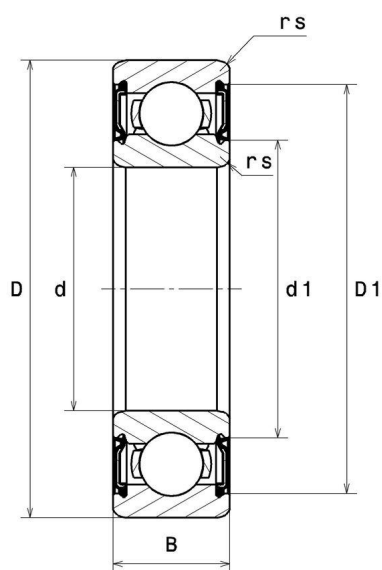
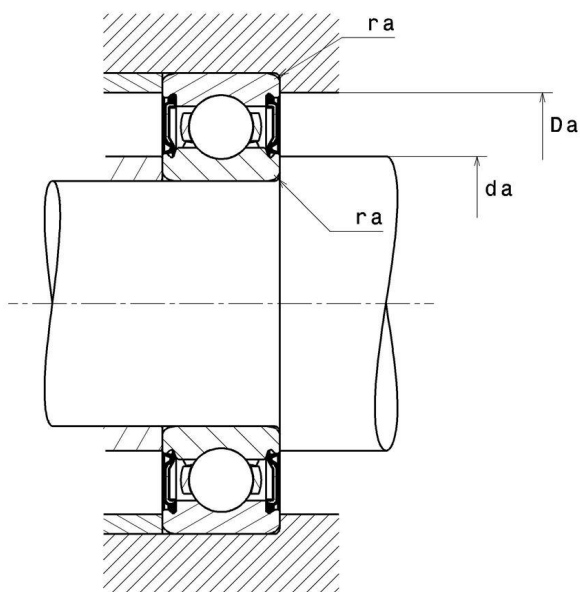

6021LLU/5K

Single row deep groove ball bearings

PRODUCT DIMENSIONS

Internal diameter (d)	105 mm
External diameter (D)	160 mm
Bearing/Inner ring width (B)	26 mm
Min fillet radius (rs)	2 mm
Radial clearance class	CM
Mass	1,59 kg
Brand	NTN

PRODUCT PERFORMANCE

Dynamic load (C)	80,5 kN
Static load (C0)	65,5 kN
Fatigue limit load (Cu)	4,15 kN
Coefficient f0	15.8
Nlim (grease)	2400 tr/min
Min operating temperature (Tmin)	-25 °C
Max operating temperature (Tmax)	110 °C

ABUTMENT

Min shoulder diameter IR (da min)	114 mm
Max shoulder diameter IR (da max)	119 mm
Max shoulder diameter OR (Da max)	151 mm
Max shaft & housing fillet radius (ra max)	2 mm

INDUSTRY CALCUL FACTORS

Equivalent dynamic radial load

$$P = X.F_r + Y.F_a$$

$\frac{f_0 F_a}{C_0}$	e	Fa / Fr ≤ e		Fa / Fr > e	
		X	Y	X	Y
0.172	0.19	1	0	0.56	2.3
0.345	0.22				1.99
0.689	0.26				1.71
1.03	0.28				1.55
1.38	0.3				1.45
2.07	0.34				1.31
3.45	0.38				1.15
5.17	0.42				1.04
6.89	0.44				1

Equivalent static radial load

$$P_0 = X_0.F_r + Y_0.F_a$$

X_0	Y_0
0.6	0.5

For single or DT bearing arrangement:

If $P_0 < F_r$, then use $P_0 = F_r$