



## Technical data

### 30318DU

Single row tapered roller bearings

Tapered roller bearing, pressed steel cage

## Visual(s)

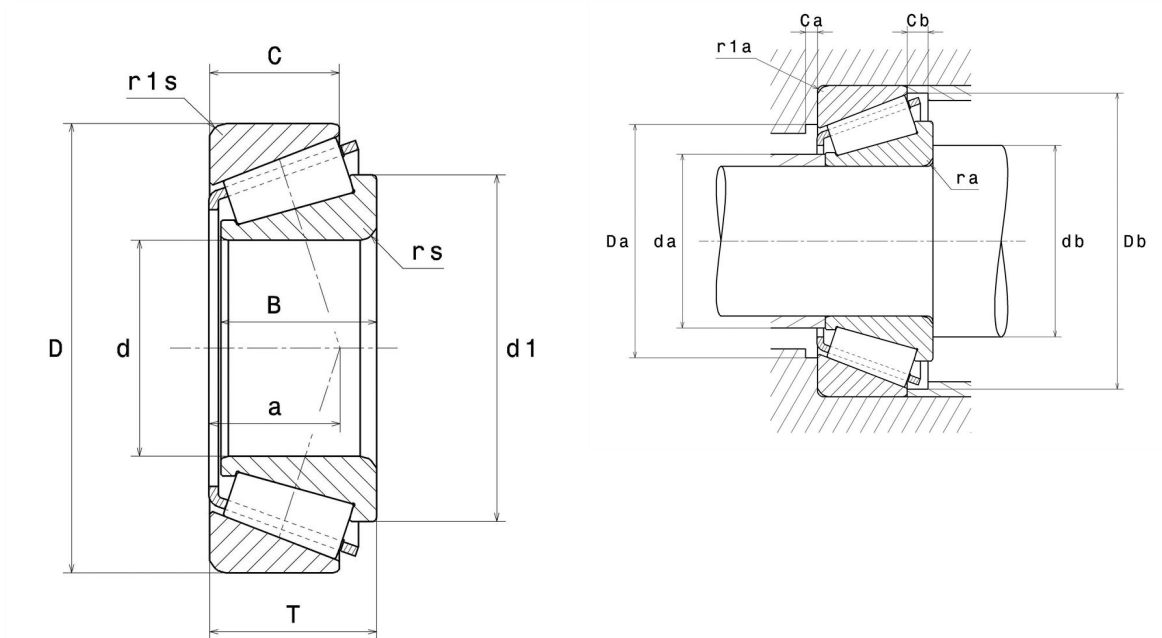

## Product definition

<b>d</b>	90 mm
<b>D</b>	190 mm
<b>B</b>	43 mm
<b>C</b>	30 mm
<b>T</b>	46.5 mm
<b>d1</b>	140 mm
<b>a</b>	59 mm
<b>rs min</b>	4 mm
<b>r1s min</b>	3 mm
<b>e</b>	0.83
<b>Y2</b>	0.73
<b>Y0</b>	0.4
<b>Mass</b>	5.66 kg
<b>ISO 355 reference</b>	T7GB090
<b>Brand</b>	NTN

## Product performance

<b>Dynamic load, C</b>	270 kN
<b>Rating life coefficient, A2</b>	1
<b>Static load, C0</b>	320 kN
<b>Fatigue limit load, Cu</b>	35.3 kN
<b>Nlim (oil)</b>	2,400 Tr/min
<b>Nlim (grease)</b>	1,800 Tr/min
<b>Min operating temperature, Tmin</b>	-40 °C
<b>Max operating temperature, Tmax</b>	120 °C
<b>Characteristic cage frequency, FTF</b>	0.42 Hz
<b>Characteristic rolling element frequency, BSF</b>	5.52 Hz
<b>Characteristic outer ring frequency, BPF0</b>	6.34 Hz
<b>Characteristic inner ring frequency, BPFI</b>	8.66 Hz

## Abutment dimensions

<b>da max</b>	109 mm
<b>db min</b>	108 mm
<b>Da min</b>	151 mm
<b>Da max</b>	176 mm
<b>Db min</b>	179 mm
<b>Ca min</b>	6 mm
<b>Cb min</b>	16.5 mm
<b>ra max</b>	3 mm
<b>r1a max</b>	2.5 mm

## Calculation factors

### Equivalent dynamic radial load

$$P = X.F_r + Y.F_a$$

$F_a / F_r \leq e$		$F_a / F_r > e$	
X	Y	X	Y
1	0	0.4	Y2

### Equivalent static radial load

$$P_0 = X_0.F_r + Y_0.F_a$$

$X_0$	$Y_0$
0.5	Y0

If  $P_0 < F_r$ , then use  $P_0 = F_r$

The values for e, Y2 and Y0 are shown in the above table