



## PASE25-XL-N

Plummer block housing unit

Schaeffler ID:  
0096423150000

Plummer block housing units PASE, cast iron housing, radial insert ball bearing with eccentric locking collar, P seals

X-life

### Technical information

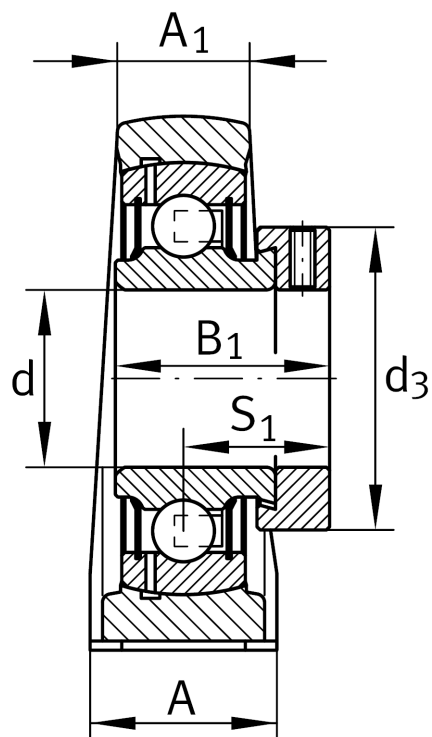
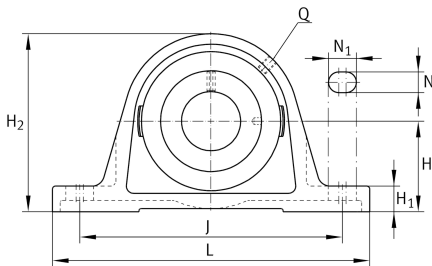

### Main Dimensions & Performance Data

d	25 mm	Bore diameter
L	130 mm	Length total
H <sub>2</sub>	70 mm	Height
	0,7 kg	Weight

### Mounting dimensions

J	102,5 mm	Distance fixing bore
N	11 mm	Width (slot)
N <sub>1</sub>	19 mm	Length (slot)

### Dimensions

H	36,5 mm	Distance shaft axis
A	36 mm	Width (base)
A <sub>1</sub>	21 mm	Width (head)
H <sub>1</sub>	14,5 mm	Height (base)
B <sub>1</sub>	31 mm	Locking collar total width
S <sub>1</sub>	23,5 mm	Distance of raceway to locking collar
Q	M6	Connection thread for lubrication

### Additional information

ASE05	Housing
GRAE25-XL-NPP-B	Bearing designation
KASK05	Protecting cap

### Temperature range

T <sub>min</sub>	-20 °C	Operating temperature min.
T <sub>max</sub>	120 °C	Operating temperature max.