

TIMKEN



TIMKEN® ANGULAR CONTACT BALL BEARING CATALOG

ABOUT THE TIMKEN COMPANY

As a global leader in bearings and power transmission systems, Timken focuses on precise solution design, materials and craftsmanship to deliver reliable and efficient performance that improves productivity and uptime. Timken offers a full range of bearings, belts, chains, couplings, gears and lubricants, along with rebuild and repair services.

Timken (NYSE; TKR; www.timken.com) applies its proven expertise in metallurgy, tribology and mechanical power transmission to create innovative approaches to customers' complex needs. Global availability of products and engineering talent, combined with exceptional service delivery across markets, makes Timken a preferred choice worldwide.

To view more Timken catalogs, go to www.timken.com/catalogs for interactive versions, or to download our catalog app to your smart phone or mobile device.

ANGULAR CONTACT BALL BEARING CATALOG INDEX

INTRODUCTION	2
HOW TO USE THIS CATALOG.....	2
SHELF LIFE AND STORAGE	3
WARNINGS.....	4

ENGINEERING

Bearing Types and Cages.....	6
Metric System Tolerances	7
Bearing Life	8
Mounting and Fitting	9
Lubrication.....	18

ANGULAR CONTACT BALL BEARINGS

Nomenclatures	20
Single-Row Angular Contact Ball Bearings.....	22
Double-Row Angular Contact Ball Bearings.....	26



TIMKEN® ANGULAR CONTACT BALL BEARINGS

ALL-AROUND RELIABILITY

Designed for reliable performance in pump, compressor, electric motor and many other industrial applications, our angular contact ball bearings are able to handle high speeds and both radial and axial loading. These bearings follow ISO standards and are dimensionally interchangeable with competitor metric products.

MORE CHOICES

We have added 250-new part numbers to our growing portfolio of single-row and double-row products. Now, you have more options from a dependable supplier known for quality and performance.

PRODUCT FEATURES

- Enhanced raceway finish
- Quiet running
- High-speed capabilities
- Robust seals
- Premium Mobil Polyrex™ EM lubricants

GET THE MOST OUT OF YOUR OPERATIONS

Every Timken angular contact ball bearing is backed by premium customer service, leveraging our global sales and distribution network. It is also supported by the knowledge of our industry-leading experts. They are ready to assist you with product design, application knowledge and field engineering support – anything you need to help improve uptime and maximize equipment performance.



HOW TO USE THIS CATALOG

We designed this catalog to help you find the Timken bearings best suited to your equipment needs and specifications.

This publication contains dimensions, tolerances and load ratings, as well as engineering sections describing fitting practices for shafts and housings, internal clearances and other bearing features. For more information, please use the Timken Engineering Manual (order no. 10424). It provides valuable assistance in the initial consideration of the type and characteristics of the bearings that may best suit your particular needs.

SHELF LIFE AND STORAGE OF GREASE-LUBRICATED BEARINGS AND COMPONENTS

To help you get the most value from our products, Timken provides guidelines for the shelf life of grease-lubricated ball and roller bearings, components and assemblies. Shelf life information is based on Timken and industry test data and experience.

SHELF LIFE

Shelf life should be distinguished from lubricated bearing component design life as follows:

Shelf life of the grease-lubricated bearing/component represents the period of time prior to use or installation.

The shelf life is a portion of the anticipated aggregate design life. It is impossible to accurately predict design life due to variations in lubricant bleed rates, oil migration, operating conditions, installation conditions, temperature, humidity and extended storage.

TIMKEN IS NOT RESPONSIBLE FOR THE SHELF LIFE OF ANY BEARING/COMPONENT LUBRICATED BY ANOTHER PARTY.

European REACH compliance

Timken lubricants, greases and similar products sold in stand alone containers or delivery systems are subject to the European REACH (Registration, Evaluation, Authorization and Restriction of Chemicals) directive. For import into the European Union, Timken can sell and provide only those lubricants and greases that are registered with ECHA (European Chemicals Agency). For further information, please contact your Timken engineer.

STORAGE

Timken suggests the following storage guidelines for our finished products (bearings, components and assemblies, referred to as "products"):

- Unless directed otherwise by Timken, products should be kept in their original packaging until they are ready to be placed into service.
- Do not remove or alter any labels or stencil markings on the packaging.

- Products should be stored in such a way that the packaging is not pierced, crushed or otherwise damaged.
- After a product is removed from its packaging, it should be placed into service as soon as possible.
- When removing a product that is not individually packaged from a bulk pack container, the container should be resealed immediately after the product is removed.
- Do not use product that has exceeded its shelf life as defined in the Timken shelf life guidelines statement.
- The storage area temperature should be maintained between 0° C (32° F) and 40° C (104° F); temperature fluctuations should be minimized.
- The relative humidity should be maintained below 60 percent and the surfaces should be dry.
- The storage area should be kept free from airborne contaminants such as, but not limited to, dust, dirt, harmful vapors, etc.
- The storage area should be isolated from undue vibration.
- Extreme conditions of any kind should be avoided.

Due to the fact that Timken is not familiar with your particular storage conditions, we strongly suggest following these guidelines. However, you may be required by circumstances or applicable government requirements to adhere to stricter storage requirements.

Most bearing components typically ship protected with a corrosion-preventive compound that is not a lubricant. These components may be used in oil-lubricated applications without removal of the corrosion-preventive compound. When using some specialized grease lubrications, we advise you to remove the corrosion-preventive compound before packing the bearing components with suitable grease.

Be careful in selecting lubrication, however, since different lubricants are often incompatible.

When you receive a bearing shipment, do not remove products from their packaging until they are ready for mounting so they do not become corroded or contaminated.

Store bearings and bearing housings in an appropriate atmosphere so they remain protected for the intended period.

**WARNING**

Failure to observe the following warnings could create a risk of death or serious injury.

Proper maintenance and handling practices are critical. Always follow installation instructions and maintain proper lubrication.

Tensile stresses can be very high in tightly fitted bearing components. Attempting to remove such components by cutting the inner ring may result in a sudden shattering of the component, causing fragments of metal to be forcefully expelled. Always use properly guarded presses or bearing pullers to remove bearings from shafts, and always use suitable personal protective equipment, including safety glasses.

CAUTION

Failure to follow these cautions may result in property damage.

The products cataloged are application-specific. Any use in applications other than those intended could lead to equipment failure or to reduced equipment life.

Use of improper bearing fits may cause damage to equipment.

Do not use damaged bearings. The use of a damaged bearing can result in equipment damage.

DISCLAIMER

This catalog is provided solely to give you analysis tools and data to assist you in your product selection. Product performance is affected by many factors beyond the control of Timken. Therefore, the suitability and feasibility of all product selection must be validated by you.

Timken products are sold subject to Timken's terms and conditions of sale, including its limited warranty and remedy, which may be found at <http://www.timken.com/termsandconditionsofsale>. Please consult with your Timken sales engineer for more information and assistance.

Every reasonable effort has been made to ensure the accuracy of the information in this writing, but no liability is accepted for errors, omissions or for any other reason.

COMPLIANCE

To view the complete engineering catalog, please visit www.timken.com. To order the catalog, please contact your Timken sales engineer and request a copy of the Timken Engineering Manual (order number 10424). For further information, please contact your Timken sales engineer.

The Timken Company products shown in this catalog may be directly or indirectly subject to a number of regulatory standards and directives originating from authorities in the USA, European Union and around the world including: REACH (EC 1907/2006, RoHS (2011/65/EU), ATEX (94/9/EC), 'CE' MARKING (93/68/EEC), CONFLICT MINERALS (Section 1502 of the Dodd-Frank Wall Street Reform and Consumer Protection Act).

For any questions or concerns regarding the compliancy or applicability of Timken products to these or other unspecified standards, please contact your Timken sales engineer or customer services representative.

Updates are made periodically to this catalog. Visit www.timken.com for the most recent version of the Timken® Angular Contact Ball Bearing Catalog.





ENGINEERING

Bearing Types and Cages.....6
 Metric System Tolerances7
 Bearing Life.....8
 Mounting and Fitting.....9
 Lubrication18

This engineering section is not intended to be comprehensive, but does serve as a useful guide in bearing selection.



*To view the complete engineering catalog and other Timken catalogs, go to **www.timken.com/catalogs** for interactive versions, or to download a catalog app for your smart phone or mobile device scan the QR code or go to **www.timkencatalogs.com**.*

BEARING TYPES AND CAGES

Angular contact ball bearings are available from Timken in single-row 7200 and 7300 series and double-row 3200 and 3300 series. Designed to take both radial and thrust loading, angular contact ball bearings are commonly used in pumps, compressors, electric motors and many other industrial applications.

Our expanded portfolio includes a range of single-row standard, single-row universally matched, and double-row designs (see table 1). These angular contact ball bearings follow ISO standards and are dimensionally interchangeable with competitor metric products.

TABLE 1.
PRODUCT TYPES

Bearing Type	Series	Bore Range	O.D. Range	Contact Angle	Tolerance	Cage Types
		mm	mm			
Single-Row Standard Design	7200	10-130	30-230	40°	Class P0	Brass or Polyamide
	7300	12-110	37-240			
Single-Row Universally Matched Design ⁽¹⁾	7200	10-130	30-230	40°	Class P5	Brass or Polyamide
	7300	12-110	37-240			
Double-Row Design ⁽²⁾	3200	12-65	32-120	30°	Class P0	Polyamide or Steel
	3300	15-70	42-150			

⁽¹⁾Designed to be used in sets.

⁽²⁾Normal clearance and C3 clearances are available for this series.

CAGES

Cages maintain uniform ball spacing in the bearing as the balls pass into and out of the load zone. They can impact several bearing operational characteristics such as:

- Maximum rotational speed
- Torque characteristics
- Temperature limits
- Lubricant flow

There are a number of different cage types that are commonly used in angular contact ball bearings. Figs. 1 and 2 show the cage variances. Table 2 describes the most common cage types.

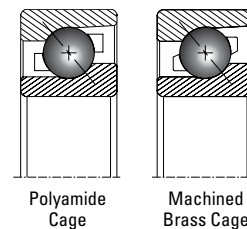

Fig. 1. Cage variants: single-row.

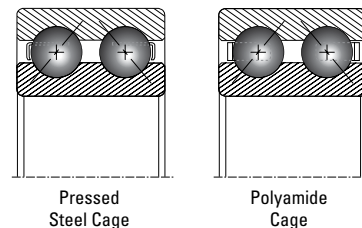

Fig. 2. Cage variants: double-row.

TABLE 2.
COMMON CAGE TYPES

Type	Molded Polymer Cage Single-Row	Machined-Brass Cage Single-Row	Polymer Crown-Type Cage Double-Row	Pressed-Steel Cage Double-Row
Design				
Construction	Made of polyamide 66 glass fiber reinforced cage; ball-piloted cage.	Made from solid brass; ball-piloted cage.	Snap-in polyamide 66 glass fiber reinforced cage; ball-piloted cage.	One-piece snap-in pressed-steel cage; ball-piloted cage.
Advantages	Designed to reduce functional torque and provide additional misalignment capability; resistant to most solvents, oils and greases.	Superior strength enables this cage to be used in heavily loaded, high-speed and high-temperature applications.	Additional misalignment capability and reduced functional torque; resistant to most solvents, oils and greases.	Rigid, strong and economical; this cage is suitable for most applications.

METRIC SYSTEM TOLERANCES

Ball bearings are manufactured to a number of specifications with each having classes that define tolerances on dimensions such as bore, outer diameter, width and runout.

Standard Timken angular contact ball bearings maintain normal tolerances (P0) according to the current ISO 492 standard. Universally matched bearings are manufactured according to P5 class tolerances.

The term “deviation” is defined as the difference between a single ring dimension and the nominal dimension. For metric tolerances, the nominal dimension is at a +0 mm tolerance. The deviation is the tolerance range for the listed parameter. Variation is defined as the difference between the largest and smallest measurement of a given parameter for an individual ring. Contact a Timken sales engineer when running tolerance is critical.

TABLE 3.
CLASS P0 INNER RING – TOLERANCES

Bearing Bore		Bore Deviation High: +0	Radial Runout	Width Deviation High: +0	Width Variation
d		Δ_{dmp}	K_{ia}	Δ_{BS}	V_{BS}
Over	Incl.	Low	Max.	Low	Max.
mm	mm	μm	μm	μm	μm
2.5	10	-8	10	-120	15
10	18	-8	10	-120	20
18	30	-10	13	-120	20
30	50	-12	15	-120	20
50	80	-15	20	-150	25
80	120	-20	25	-200	25
120	150	-25	30	-250	30
150	180	-25	30	-250	30
180	250	-30	40	-300	30
250	315	-35	50	-350	35
315	400	-40	60	-400	40

TABLE 4.
CLASS P0 OUTER RING – TOLERANCES

Bearing O.D.		Outside Deviation High: +0	Radial Runout	Width Deviation High: +0	Width Variation
D		Δ_{Dmp}	K_{ea}	Δ_{CS}	V_{CS}
Over	Incl.	Low	Max.	Low	Max.
mm	mm	μm	μm	μm	μm
6	18	-8	15		
18	30	-9	15		
30	50	-11	20		
50	80	-13	25		
80	120	-15	35		
120	150	-18	40		
150	180	-25	45		
180	250	-30	50		
250	315	-35	60		
315	400	-40	70		
400	500	-45	80		

Identical to Δ_{BS} of the inner ring of the same bearing

Identical to V_{BS} of the inner ring of the same bearing

TABLE 5.
CLASS P5 INNER RING – TOLERANCES

Bearing Bore		Bore Deviation High: +0	Radial Runout	Face Runout to Bore	Axial Runout	Width Deviation High: +0		Width Variation
d		Δ_{dmp}	K_{ia}	S_d	S_{ia}	Δ_{BS}	$\Delta_{BSu}^{(1)}$	V_{BS}
Over	Incl.	Low	Max.	Max.	Max.	Low		Max.
mm	mm	μm	μm	μm	μm	μm	μm	μm
2.5	10	-5	4	7	7	-40	-250	5
10	18	-5	4	7	7	-80	-250	5
18	30	-6	4	8	8	-120	-250	5
30	50	-8	5	8	8	-120	-250	5
50	80	-9	5	8	8	-150	-250	6
80	120	-10	6	9	9	-200	-380	7
120	150	-13	8	10	10	-250	-380	8
150	180	-13	8	10	10	-250	-380	8
180	250	-15	10	11	13	-300	-500	10
250	315	-18	13	13	15	-350	-500	13
315	400	-23	15	15	20	-400	-630	15

⁽¹⁾Applies to single-row universally matched design.

TABLE 6.
CLASS P5 OUTER RING – TOLERANCES

Bearing O.D.		Outside Deviation High: +0	Radial Runout	Face Runout to Bore	Axial Runout	Width Deviation High: +0		Width Variation
D		Δ_{Dmp}	K_{ea}	S_D	S_{ea}	Δ_{CS}	$\Delta_{CSu}^{(1)}$	V_{CS}
Over	Incl.	Low	Max.	Max.	Max.	Low		Max.
mm	mm	μm	μm	μm	μm	μm	μm	μm
6	18	-5	5	8	8			5
18	30	-5	6	8	8			5
30	50	-6	7	8	8			5
50	80	-8	8	8	10			5
80	120	-9	10	9	11			6
120	150	-10	11	10	13			7
150	180	-13	13	10	14			8
180	250	-13	15	11	15			8
250	315	-15	18	13	18			10
315	400	-18	20	13	20			13
400	500	-23	23	15	23			15

Identical to Δ_{BS} of the inner ring of the same bearing

⁽¹⁾Applies to single-row universally matched design.

BEARING LIFE

The selection of the appropriate bearing for a given application is dependent on several performance criteria. These include bearing fatigue life, rotating precision, power loss requirement, temperature limits, speed capabilities and sound requirements. This section deals primarily with bearing life as related to material-associated fatigue.

Bearing life is defined as the length of time, or number of revolutions, until a fatigue spall of 6 mm² develops. Since fatigue is a statistical phenomenon, the life of an individual bearing is impossible to predetermine precisely. Bearings that may appear to be identical can exhibit considerable life scatter when tested under identical conditions. Thus, it is necessary to base life predictions on a statistical evaluation of a large number of bearings operating under similar conditions. The Weibull distribution function is the accepted standard for predicting the life of a population of bearings at any given reliability level.

RATING LIFE

Rating life (L_{10}) is the life that 90 percent of a group of apparently identical bearings will complete or exceed before a fatigue spall reaching criteria develops. The L_{10} life also is associated with 90 percent reliability for a single bearing under a certain load.

DYNAMIC LOAD RATING

Published dynamic load ratings for angular contact ball bearings are based on the industry standard procedure outlined in ISO 281:2007. This rating is designated as C_r and is defined as the radial load under which a population of bearings will achieve a L_{10} life of one million revolutions. Radial load is assumed to be constant in magnitude and direction for radial ball bearings.

STATIC LOAD RATING

The standard static load rating for Timken bearings (designated as C_{0r}) as defined in ISO 76:2006 is based on a maximum contact stress within a non-rotating bearing of 4200 MPa at the center of the most heavily loaded rolling element and raceway contact.

Such stress levels may cause visible light Brinell marks on the bearing raceways. This degree of marking will not have a measurable effect on fatigue life when the bearing is subsequently rotated under a lower application load. If sound, vibration or torque are critical or if a pronounced shock load is present, a lower load limit should be applied. For more information on selecting a bearing for static load conditions, consult your Timken sales engineer.

SPEED RATING

THERMAL REFERENCE SPEED

The thermal reference speed is the bearing thermal equilibrium speed based on industry standard reference conditions outlined in ISO 15312: 2003. Thermal equilibrium balances the heat generated by the bearing, with heat conduction through the housing and shaft. This standard applies to both bath oil lubricated and 30 percent grease fill packed bearings. It excludes any heat removed by a circulating lubricant. This standard also excludes the outer ring rotating application and heat generated by contact seals.

The ISO 15312 thermal reference speed rating calculations are based on the following assumptions:

- The bearing ambient temperature is 20° C.
- The tolerable bearing/housing interface temperature is 70° C.
- Oil and grease lubricants are considered.
 - For radial bearings with oil lubrication: ISO VG 32 oil.
 - For radial bearings with grease lubrication: ISO VG 150 grease.
- The radial loads assume a normal clearance (CO or CN).
- For radial bearings, the applied load is 5 percent of the static load rating (C_{0r}).

Thermal reference speed ratings assume the bearing has been sufficiently broken in. During the break-in process, temperatures may exceed the tolerable limit. Break-in commonly takes between 10 to 36 hours.

Standard bearing materials and lubricants can generally withstand temperatures up to and beyond 100° C. For this reason, a permissible temperature of 100° C was assumed for the thermal speed rating calculation. Contact your Timken sales engineer if your application requires speeds above the Timken published values.

LIMITING SPEED

The limiting speeds for single- and double-row open bearings are listed in the product data section (pages 23 to 27). The values depend on grease or oil lubrication, and on the various designs of open, sealed, and shielded configurations. The values listed for single-row designs reflect the lubrication types and are valid only for open bearing design configuration. For the double-row sealed bearing configuration, the seals themselves become the limiting factor due to the additional heat generation at the contact points; therefore the grease speed values take into account the seals. The values listed for double-row bearings with oil lubrication are for the open bearing configuration.

MOUNTING AND FITTING

SINGLE-ROW BEARING DESIGN

Single-row angular contact ball bearings are designed to handle radial and axial loads simultaneously. However, they can only accommodate axial loads in one direction. As a result, most single-row angular contact ball bearings are mounted in pairs. Single-row angular contact ball bearings are available in either standard or universally matched designs.

In angular contact ball bearing design, the forces are transmitted from one raceway to the other along a given contact angle. This angle is defined as the angle between the line of action of forces and a radial plane (Fig. 3). The result is a larger contact angle increasing the bearing's axial load capability.

α = Contact angle

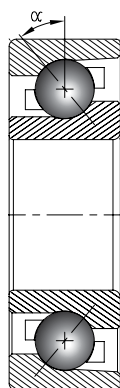

Fig. 3. Single-row bearing design.

CONTACT ANGLE

The contact angle of an angular contact ball bearing is the angle between a line through the ball center perpendicular to the bearing axis and a line through the two points where the ball contacts the races when the bearing axial play is removed.

Timken single-row angular contact ball bearings of series 7200 and 7300 have a contact angle of 40 degrees and Timken double-row angular contact ball bearings of series 3200 and 3300 have a contact angle of 30 degrees which allow them to accommodate high axial loads.

STANDARD DESIGN

Standard design angular contact ball bearings are in applications when one bearing is used for each bearing side. The mounting can be either back-to-back (DB, Fig. 4) or face-to-face (DF, Fig. 5). Because standard design bearings need to be adjusted for optimum performance, they are not suitable to mount immediately adjacent to each other.

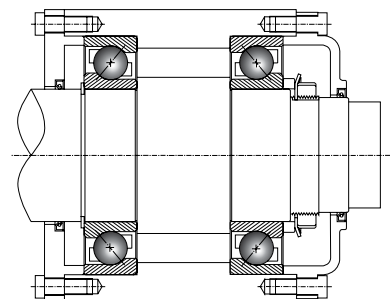

Fig. 4. Two single angular contact ball bearings in standard DB arrangement.

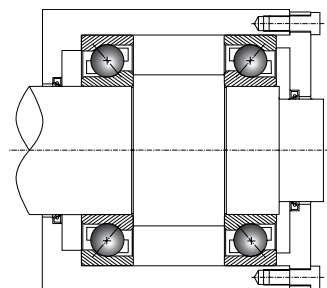

Fig. 5. Two single angular contact ball bearings in standard DF arrangement.

UNIVERSALLY MATCHED DESIGN

Universally matched angular contact ball bearings, which are intended for fitting in pairs, have width and standout of the rings manufactured to closer tolerances. The bearings can be fitted in back-to-back (DB), face-to-face (DF), or tandem arrangement (DT).

The bearings are ground to achieve pre-defined clearances/preloads, and adjustment is achieved directly by clamping the bearings. This results in uniform load distribution between the paired bearings and eliminates the need for spacers or shims.

The universally matched bearings have a suffix indicating the axial clearance and preload values:

- Axial clearance
 - CN** - Normal
 - CS** - Smaller than normal
 - CL** - Larger than normal
- Preload
 - UL** - Light
 - UM** - Medium
 - UH** - Heavy

The axial clearances and preload values corresponding to these suffixes are given in table 8 on page 12.

BACK-TO-BACK (DB) ARRANGEMENT

Bearings in a back-to-back arrangement can accommodate axial loads in either direction and have the highest moment/tilting load-handling capability owing to an increased bearing spread. With increasing operating temperatures, the radial shaft expansion tends to increase the bearing preload. However, the resulting axial growth allows the bearings to move apart to balance the expansion, thereby mitigating the increase in preload. Therefore this type of this type of arrangement is best-suited for and most commonly used for high-temperature and high-speed applications.

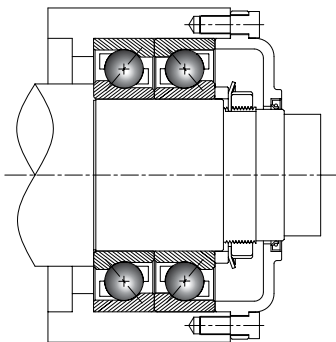

Fig. 6. Back-to-back (DB) arrangement.

FACE-TO-FACE (DF) ARRANGEMENT

Bearings in face-to-face arrangement also accommodate axial loads in either direction, but with reduced stiffness as provided by the back-to-back arrangement. This type of arrangement is not suitable for high-temperature usage applications as the preload in the bearings tends to increase with radial and axial shaft growth.

Since the face-to-face mounting has inherent disadvantages it should only be considered with proper application analysis and if required due to assembly constraints.

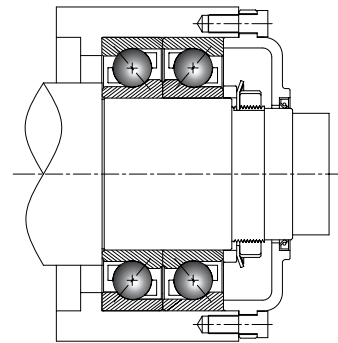

Fig. 7. Face-to-face (DF) arrangement.

TANDEM (DT) ARRANGEMENT

Bearings in tandem arrangement can accommodate loads in only one direction and are used when the required load-carrying capacity exceeds that of a single bearing. Tandem sets must be adjusted against another bearing in order to completely constrain the system.

More than two bearings can be used in tandem if additional load-carrying capability is required.

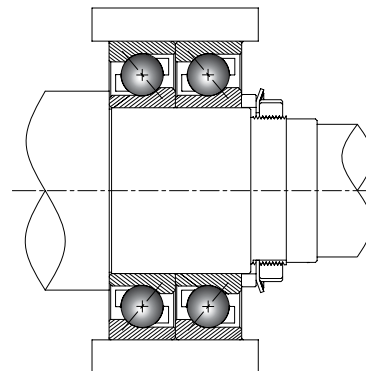

Fig. 8 Tandem (DT) arrangement.

DOUBLE-ROW BEARING DESIGN AND CONFIGURATIONS

Double-row angular contact ball bearings consist of two single-row angular contact ball bearings in back-to-back (DB) arrangement with integral double inner and outer rings. Double-row bearings require less axial space than two single-row bearings and can take radial loads as well as axial loads in both directions. The back-to-back arrangement provides a high moment/tilting load-handling capability.

Double-row angular contact ball bearings can be open on both sides, or closed by seals (2RS suffix) or shields (ZZ suffix).

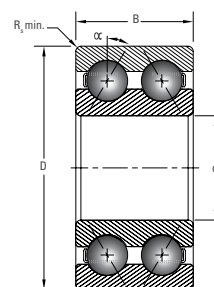

Fig. 9. Double-row bearing design.

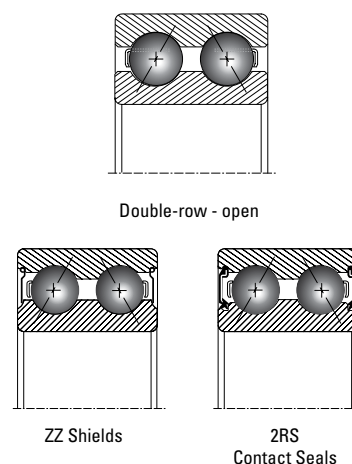
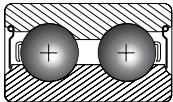
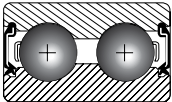

Fig. 10. Double-row bearing configurations.

TABLE 7.
CHARACTERISTICS OF SHIELDS AND SEALS

Type	Shields ZZ	Contact Seals 2RS
Construction		
Material	Low-carbon pressed steel	Nitrile (Buna-N) rubber with steel insert
Speed Capability	High speed	Less than shielded bearing
Operating Temperature	-50° C to +120° C	-40° C to +120° C
Grease Retention	Good	Excellent
Dust Resistance	Good	Excellent
Torque	Low	Greater than shielded bearing

AXIAL CLEARANCE

Axial clearance for universally matched bearings when arranged face-to-face (DF) or back-to-back (DB).

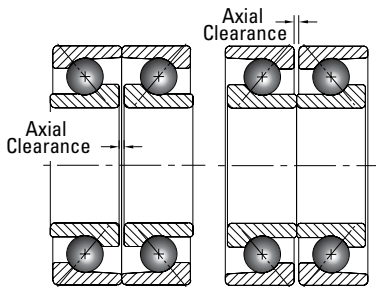

Fig. 11. Axial clearance for universally matched bearings.

AXIAL PRELOAD

Light, medium and heavy preloads for universally matched bearings when arranged back-to-back (DB) or face-to-face (DF).

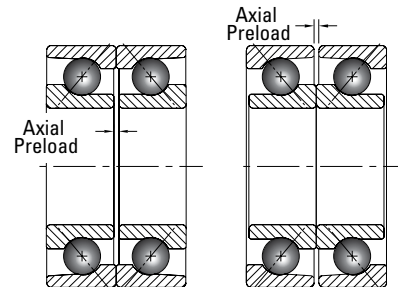

Fig. 12. Axial preload for universally matched bearings.

TABLE 8.
AXIAL CLEARANCE AND PRELOAD OF SINGLE-ROW UNIVERSALLY MATCHED

Bore Diameter (d)		Axial Clearance for Pairs					
		CS		CN		CL	
Over	Incl.	Min.	Max.	Min.	Max.	Min.	Max.
mm		µm	µm	µm	µm	µm	µm
1	18	5	13	15	23	24	32
18	30	7	15	18	26	32	40
30	50	9	17	22	30	40	48
50	80	11	23	26	38	48	60
80	120	14	26	32	44	55	67
120	160	17	29	35	47	62	74

Bore Diameter (d)		Preload Values for Pairs					
		UL		UM		UH	
Over	Incl.	Min.	Max.	Min.	Max.	Min.	Max.
mm		µm	µm	µm	µm	µm	µm
1	18	4	-4	-2	-10	-8	-16
18	30	4	-4	-2	-10	-8	-16
30	50	4	-4	-2	-10	-8	-16
50	80	6	-6	-3	-15	-12	-24
80	120	6	-6	-3	-15	-12	-24
120	160	6	-6	-3	-15	-12	-24

DOUBLE-ROW AXIAL CLEARANCE

TABLE 9.
AXIAL INTERNAL CLEARANCE OF DOUBLE-ROW ANGULAR CONTACT BALL BEARINGS

Bore Diameter		Axial Internal Clearance							
		C2		C0		C3		C4	
Over	Incl.	Min.	Max.	Min.	Max.	Min.	Max.	Min.	Max.
mm		µm	µm	µm	µm	µm	µm	µm	µm
1	10	1	11	5	21	12	28	25	45
10	18	1	12	6	23	13	31	27	47
18	24	2	14	7	25	16	34	28	48
24	30	2	15	8	27	18	37	30	50
30	40	2	16	9	29	21	40	33	54
40	50	2	18	11	33	23	44	36	58
50	65	3	22	13	36	26	48	40	63
65	80	3	24	15	40	30	54	46	71

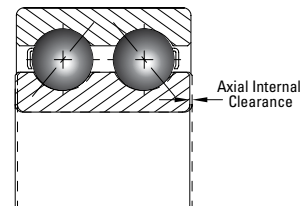

Fig. 13. Double-row axial clearance.

FITTING PRACTICES

As a general guideline, bearing rings mounted on a rotating member should have an interference fit. Loose fits may permit the ring to creep or turn and wear the mating surface and backing shoulder. This wear can result in excessive bearing looseness and damage the bearing, shaft or housing.

The choice of fitting practices will mainly depend upon the following parameters:

- Precision class of the bearing.
- Rotating or stationary ring.
- Type of layout (single- or double-row bearings).
- Type and direction of load (continuous/alternate rotating).
- Particular running conditions like shocks, vibrations, over-loading or high speed.
- Capability for machining the bearing seats (grinding, turning or boring).
- Shaft and housing section and material.
- Mounting and setting conditions.

Fig. 14 is a graphical representation of bearing shaft and housing fit selection that conforms to accepted industry standards and practices. The bars designated g6, h6, etc., represent shaft/housing diameter and tolerance ranges to achieve various loose and interference fits required for various load and ring rotation conditions.

Tables 10 and 11, on the following pages, provide the resultant fits based on standard ISO tolerances for shaft and housing.

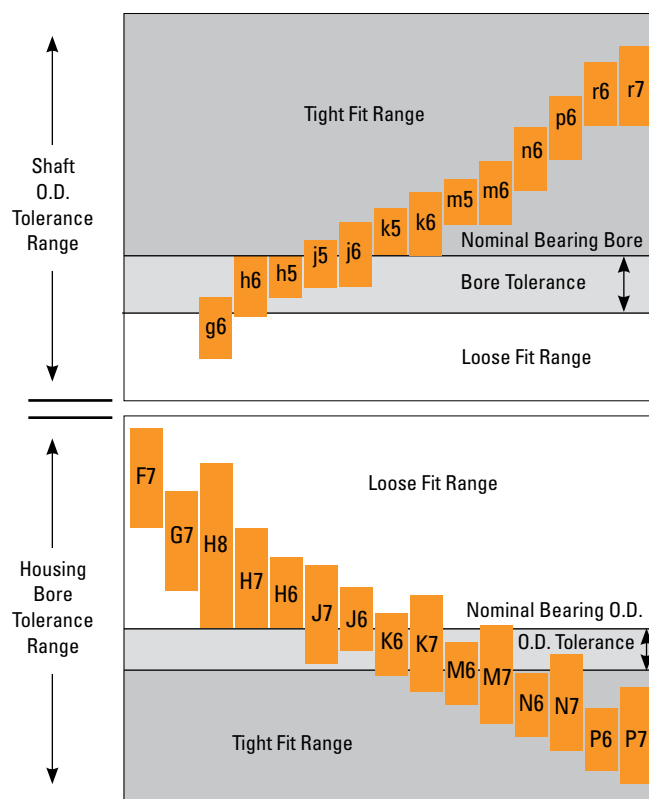

Fig. 14. Bearing shaft and housing fit selections.

SHAFT AND HOUSING FITS

SHAFT TOLERANCES: ANGULAR CONTACT BALL BEARINGS

TABLE 10.
SHAFT TOLERANCES: ANGULAR CONTACT BALL BEARINGS

Bearing Bore		g6				h5			h6			j5			js5			js6			j6			
Nominal (Max.)	Tolerance	Shaft Diameter		Fit	Shaft Diameter		Fit	Shaft Diameter		Fit	Shaft Diameter		Fit	Shaft Diameter		Fit	Shaft Diameter		Fit	Shaft Diameter		Fit		
		Max.	Min.		Max.	Min.		Max.	Min.		Max.	Min.		Max.	Min.		Max.	Min.		Max.	Min.		Max.	Min.
Over	Incl.	µm		µm		µm		µm		µm		µm		µm		µm		µm		µm				
-	3	0	-5	-2	-8	-8L 3T	0	-4	-4L 5T	0	6	6L 5T	2	-2	2L 7T	2	-2	2L 7T	3	-3	3L 8T	4	-2	2L 9T
3	6	0	-5	-4	-12	12L 1T	0	-5	5L 5T	0	-8	8L 5T	3	-2	2L 8T	2.5	-2.5	2.5L 7.5T	4	-4	4L 9T	6	-2	2L 11T
6	10	0	-5	-5	-14	14L 0L	0	-6	6L 5T	0	-9	9L 5T	4	-2	2L 9T	3	-3	3L 8T	4.5	-4.5	4.5L 9.5T	7	-2	2L 12T
10	18	0	-5	-6	-17	17L 1L	0	-8	8L 5T	0	-11	11L 5T	5	-3	3L 10T	4	-4	4L 9T	5.5	-5.5	5.5L 10.5T	8	-3	3L 13T
18	30	0	-6	-7	-20	20L 1L	0	-9	9L 6T	0	-13	13L 6T	5	-4	4L 11T	4.5	-4.5	4.5L 10.5T	6.5	-6.5	6.5L 12.5T	9	-4	4L 15T
30	50	0	-8	-9	-25	25L 1L	0	-11	11L 8T	0	-16	16L 8T	6	-5	5L 14T	5.5	-5.5	5.5L 13.5T	8	-8	8L 16T	11	-5	5L 19T
50	80	0	-9	-10	-29	29L 1L	0	-13	13L 9T	0	-19	19L 9T	6	-7	7L 15T	6.5	-6.5	6.5L 15.5T	9.5	-9.5	9.5L 18.5T	12	-7	7L 21T
80	120	0	-10	-12	-34	34L 2L	0	-15	15L 10T	0	-22	22L 10T	6	-9	9L 16T	7.5	-7.5	7.5L 17.5T	11	-11	11L 21T	13	-9	9L 23T
120	180	0	-13	-14	-39	39L 1L	0	-18	18L 13T	0	-25	25L 13T	7	-11	11L 20T	9	-9	9L 22T	12.5	-12.5	12.5L 25.5T	14	-11	11L 27T
180	200	0	-15	-15	-44	44L 0L	0	-20	20L 15T	0	-29	29L 15T	7	-13	13L 22T	10	-10	10L 25T	14.5	-14.5	14.5L 29.5T	16	-13	13L 31T
200	225	0	-15	-15	-44	44L 0L	0	-20	20L 15T	0	-29	29L 15T	7	-13	13L 22T	10	-10	10L 25T	14.5	-14.5	14.5L 29.5T	16	-13	13L 31T
225	250	0	-15	-15	-44	44L 0L	0	-20	20L 15T	0	-29	29L 15T	7	-13	13L 22T	10	-10	10L 25T	14.5	-14.5	14.5L 29.5T	16	-13	13L 31T
250	280	0	-18	-17	-49	49L 1T	0	-23	23L 18T	0	-32	32L 18T	7	-16	16L 25T	11.5	-12	11.5L 29.5T	16	-16	16L 34T	16	-16	16L 34T
280	315	0	-18	-17	-49	49L 1T	0	-23	23L 18T	0	-32	32L 18T	7	-16	16L 25T	11.5	-12	11.5L 29.5T	16	-16	16L 34T	16	-16	16L 34T
315	355	0	-23	-18	-54	54L 5T	0	-25	25L 23T	0	-36	36L 23T	7	-18	18L 30T	12.5	-13	12.5L 35.5T	18	-18	18L 41T	18	-18	18L 41T
355	400	0	-23	-18	-54	54L 5T	0	-25	25L 23T	0	-36	36L 23T	7	-18	18L 30T	12.5	-13	12.5L 35.5T	18	-18	18L 41T	18	-18	18L 41T

NOTE: L = loose fit; T = tight (or interference) fit.

TABLE 10.
SHAFT TOLERANCES: ANGULAR CONTACT BALL BEARINGS - CONTINUED

k5			k6			m5			m6			n6			p6			r6			r7		
Shaft Diameter		Fit	Shaft Diameter		Fit	Shaft Diameter		Fit	Shaft Diameter		Fit	Shaft Diameter		Fit	Shaft Diameter		Fit	Shaft Diameter		Fit	Shaft Diameter		Fit
Max.	Min.		Max.	Min.		Max.	Min.		Max.	Min.		Max.	Min.		Max.	Min.		Max.	Min.		Max.	Min.	
µm			µm			µm			µm			µm			µm			µm					
4	0	0T 9T	6	0	0T 11T	6	2	2T 11T	8	2	22T 13T	-	-	-	-	-	-	-	-	-	-	-	
6	1	1T 11T	9	1	1T 14T	9	4	4T 14T	12	4	4T 17T	16	8	8T 21T	20	12	12T 25T	23	15	15T 28T	27	15	15T 32T
7	1	1T 12T	10	1	1T 15T	12	6	6T 17T	15	6	6T 20T	19	10	10T 24T	24	15	15T 29T	28	19	19T 33T	34	19	19T 39T
9	1	1T 14T	12	1	1T 17T	15	7	7T 20T	18	7	7T 23T	23	12	12T 28T	29	18	18T 34T	34	23	23T 39T	41	23	23T 46T
11	2	2T 17T	15	2	2T 21T	17	8	8T 23T	21	8	8T 27T	28	15	15T 34T	35	22	22T 41T	41	28	28T 47T	49	28	28T 55T
13	2	2T 21T	18	2	2T 26T	20	9	9T 28T	25	9	9T 33T	33	17	17T 41T	42	26	26T 50T	50	34	34T 58T	59	34	34T 67T
15	2	2T 24T	21	2	2T 30T	24	11	11T 33T	30	11	11T 39T	39	20	20T 48T	51	32	32T 60T	62	41	41T 71T	73	41	41T 82T
18	3	3T 28T	25	3	3T 35T	28	13	13T 38T	35	13	13T 45T	45	23	23T 55T	59	37	37T 69T	76	51	51T 86T	89	51	51T 99T
21	3	3T 34T	28	3	3T 41T	33	15	15T 46T	40	15	15T 53T	52	27	27T 65T	68	43	43T 81T	90	65	65T 103T	105	65	65T 118T
24	4	4T 39T	33	4	4T 48T	37	17	17T 52T	46	17	17T 61T	60	31	31T 75T	79	50	50T 94T	106	77	77T 121T	123	77	77T 138T
24	4	4T 39T	33	4	4T 48T	37	17	17T 52T	46	17	17T 61T	60	31	31T 75T	79	50	50T 94T	109	80	80T 124T	126	80	80T 141T
24	4	4T 39T	33	4	4T 48T	37	17	17T 52T	46	17	17T 61T	60	31	31T 75T	79	50	50T 94T	113	84	84T 128T	130	84	84T 145T
27	4	4T 45T	36	4	4T 54T	43	20	20T 61T	52	20	20T 70T	66	34	34T 84T	88	56	56T 106T	126	94	94T 144T	146	94	94T 164T
27	4	4T 45T	36	4	4T 54T	43	20	20T 61T	52	20	20T 70T	66	34	34T 84T	88	56	56T 106T	130	98	98T 148T	150	98	98T 168T
29	4	4T 52T	40	4	4T 63T	46	21	21T 69T	57	21	21T 80T	73	37	37T 96T	98	62	62T 121T	144	108	108T 167T	165	108	108T 188T
29	4	4T 52T	40	4	4T 6 3T	46	21	21T 69T	57	21	21T 80T	73	37	37T 96T	98	62	62T 121T	150	114	114T 173T	171	114	114T 194T

NOTE: L = loose fit; T = tight (or interference) fit.

HOUSING TOLERANCES: ANGULAR CONTACT BALL BEARINGS

TABLE 11.
HOUSING TOLERANCES: ANGULAR CONTACT BALL BEARINGS

Bearing O.D.		F7					G7			H6			H7			H8			J6			J7		
Nominal (Max.)	Tolerance	Housing Bore		Fit	Housing Bore		Fit	Housing Bore		Fit	Housing Bore		Fit	Housing Bore		Fit	Housing Bore		Fit	Housing Bore		Fit		
		Over	Incl.		Max.	Min.		Max.	Min.		Max.	Min.		Max.	Min.		Max.	Min.		Max.	Min.		Max.	Min.
mm		µm		µm			µm			µm			µm			µm			µm			µm		
6	10	0	-5	28	13	13L 33L	20	5	5L 25L	9	0	0L 14L	15	0	0L 20L	22	0	0L 27L	5	-4	4T 10L	8	-7	7T 13L
10	18	0	-5	34	16	16L 39L	24	6	6L 29L	11	0	0L 16L	18	0	0L 23L	27	0	0L 32L	6	-5	5T 11L	10	-8	8T 15L
18	30	0	-6	41	20	20L 47L	28	7	7L 34L	13	0	0L 19L	21	0	0L 27L	33	0	0L 39L	8	-5	5T14L	12	-9	9T 18L
30	50	0	-7	50	25	25L 57L	34	9	9L 41L	16	0	0L 23L	25	0	0L 32L	39	0	0L 46L	10	-6	6T 17L	14	-11	11T 21L
50	80	0	-9	60	30	30L 69L	40	10	10L 49L	19	0	0L 28L	30	0	0L 39L	46	0	0L 55L	13	-6	6T 22L	18	-12	12T 27L
80	120	0	-10	71	36	36L 81L	47	12	12L 57L	22	0	0L 32L	35	0	0L 45L	54	0	0L 64L	16	-6	6T 26L	22	-13	13T 32L
120	150	0	-11	83	43	43L 94L	54	14	14L 65L	25	0	0L 36L	40	0	0L 51L	63	0	0L 74L	18	-7	7T 29L	26	-14	14T 37L
150	180	0	-13	83	43	43L 96L	54	14	14L 67L	25	0	0L 38L	40	0	0L 53L	63	0	0L 76L	18	-7	7T 31L	26	-14	14T 39L
180	250	0	-15	96	50	50L 111L	61	15	15L 76L	29	0	0L 44L	46	0	0L 61L	72	0	0L 87L	22	-7	7T 37L	30	-16	16T 45L
250	315	0	-18	108	56	56L 126L	69	17	17L 87L	32	0	0L 50L	52	0	0L 70L	81	0	0L 99L	25	-7	7T 43L	36	-16	16T 54L
315	400	0	-20	119	62	62L 139L	75	18	18L 95L	36	0	0L 56L	57	0	0L 77L	89	0	0L 109L	29	-7	7T 49L	39	-18	18T 59L
400	500	0	-23	131	68	68L 154L	83	20	20L 106L	40	0	0L 63L	63	0	0L 86L	97	0	0L 120L	33	-7	7T 56L	43	-20	20T 66L
500	630	0	-28	146	76	76L 174L	92	22	22L 120L	44	0	0L 72L	70	0	0L 98L	110	0	0L 138L	37	-7	7T 65L	48	-22	22T 76L
630	800	0	-35	160	80	80L 195L	104	24	24L 139L	50	0	0L 85L	80	0	0L 115L	125	0	0L 160L	40	-10	10T 75L	56	-24	24T 91L

NOTE: L = loose fit; T = tight (or interference) fit.

TABLE 11.
HOUSING TOLERANCES: ANGULAR CONTACT BALL BEARINGS - CONTINUED

JS6			K6			K7			M6			M7			N6			N7			P6			P7		
Shaft Diameter		Fit	Shaft Diameter		Fit	Shaft Diameter		Fit	Shaft Diameter		Fit	Shaft Diameter		Fit	Shaft Diameter		Fit	Shaft Diameter		Fit	Shaft Diameter		Fit			
Max.	Min.		Max.	Min.		Max.	Min.		Max.	Min.		Max.	Min.		Max.	Min.		Max.	Min.		Max.	Min.		Max.	Min.	Max.
µm			µm			µm			µm			µm			µm			µm			µm					
4.5	-4.5	4.5T 9.5L	2	-7	7T 7L	5	-10	10T 10L	-3	-12	12T 2L	0	-15	15T 5L	-7	-16	16T 2T	-4	-19	19T 1L	-12	-21	21T 7T	-9	-24	24T 4T
5.5	-5.5	5.5T 10.5L	2	-9	9T 7L	6	-12	12T 11L	-4	-15	15T 1L	0	-18	18T 5L	-9	-20	20T 4T	-5	-23	23T 0L	-15	-26	26T 10T	-11	-29	29T 6T
6.5	-6.5	6.5T 12.5L	2	-11	11T 8L	6	-15	15T 12L	-4	-17	17T 2L	0	-21	21T 6L	-11	-24	24T 5T	-7	-28	28T 1T	-18	-31	31T 12T	-14	-35	35T 8T
8	-8	8T 15L	3	-13	13T 10L	7	-18	18T 14L	-4	-20	20T 3L	0	-25	25T 7L	-12	-28	28T 5T	-8	-33	33T 1T	-21	-37	37T 14T	-17	-42	42T 10T
9.5	-9.5	9.5T 18.5L	4	-15	15T 13L	9	-21	21T 18L	-5	-24	24T 4L	0	-30	30T 9L	-14	-33	33T 5T	-9	-39	39T 0L	-26	-45	45T 17T	-21	-51	51T 12T
11	-11	11T 21L	4	-18	18T 14L	10	-25	25T 20L	-6	-28	28T 4L	0	-35	35T 10L	-16	-38	38T 6T	-10	-45	45T 0L	-30	-52	52T 20T	-24	-59	59T 14T
12.5	-12.5	12.5T 23.5L	4	-21	21T 15L	12	-28	28T 23L	-8	-33	33T 3L	0	-40	40T 11L	-20	-45	45T 9T	-12	-52	52T 1T	-36	-61	61T 25T	-28	-68	68T 17T
12.5	-12.5	12.5T 25.5L	4	-21	21T 17L	12	-28	28T 25L	-8	-33	33T 5L	0	-40	40T 13L	-20	-45	45T 7T	-12	-52	52T 1L	-36	-61	61T 23T	-28	-68	68T 15T
14.5	-14.5	14.5T 29.5L	5	-24	24T 20L	13	-33	33T 28L	-8	-37	37T 7L	0	-46	46T 15L	-22	-51	51T 7T	-14	-60	60T 1L	-41	-70	70T 26T	-33	-79	79T 18T
16	-16	16T 34L	5	-27	27T 23L	16	-36	36T 34L	-9	-41	41T 9L	0	-52	52T 18L	-25	-57	57T 7T	-14	-66	66T 4L	-47	-79	79T 29T	-36	-88	88T 18T
18	-18	18T 38L	7	-29	29T 27L	17	-40	40T 37L	-10	-46	46T 10L	0	-57	57T 20L	-26	-62	62T 6T	-16	-73	73T 4L	-51	-87	87T 31T	-41	-98	98T 21T
20	-20	20T 43L	8	-32	32T 31L	18	-45	45T 41L	-10	-50	50T 13L	0	-63	63T 23L	-27	-67	67T 4T	-17	-80	80T 6L	-55	-95	95T 32T	-45	-108	108T 22T
22	-22	22T 50L	0	-44	44T 28L	0	-70	70T 28L	-26	-70	70T 2L	-26	-96	96T 2L	-44	-88	88T 16T	-44	-114	114T 16T	-78	-122	122T 50T	-78	-148	148T 50T
25	-25	25T 60L	0	-50	50T 35L	0	-80	80T 35L	-30	-80	80T 5L	-30	-110	110T 5L	-50	-100	100T 15T	-50	-130	130T 15T	-88	-138	138T 53T	-88	-168	168T 53T

NOTE: L = loose fit; T = tight (or interference) fit.

LUBRICATION

Bearings must be lubricated to minimize friction between balls and raceways, as well as between balls and cages. Lubricants also help protect the bearings from corrosion and, in some cases, to dissipate heat.

Timken single-row open and double-row open angular contact ball bearings are covered with rust preventive (RP) covering all bearing surfaces. For such bearings, the end user selects and applies the desired lubrication type and quantity as required by the application.

Timken double-sealed and shielded angular contact ball bearings are covered with RP and factory pre-lubricated with water-resistant grease chosen for chemical and mechanical stability. The standard grease is Mobil Polyrex EM. This is a mineral-oil based, advanced polyurea-thickened grease that maintains proper lubrication for a wide range of operating

temperatures from -29° C to 120° C. Mobil Polyrex EM provides protection against rust and corrosion, and additional protection under mild salt-water wash conditions. This grease also is widely preferred in electric motor applications.

The standard factory grease fill is 30 to 50 percent of bearing free volume for Timken double-sealed/shielded ball bearings. The type and amount of grease needed varies depending on operating conditions and bearing series. Most bearings can be filled with customer-specified greases upon request to meet specific application needs. Aside from Mobil Polyrex EM grease, Timken also offers a range of other proven and popular greases suitable for a wide range of applications. Contact a Timken sales engineer for more details.

Table 12 is an overview of the common characteristics for the grease used in this product.

**TABLE 12.
LUBRICATION**

Product Name	Brand Name	Min. Temp	Max. Temp	Base Oil Type	Thickener	Color	Characteristics and Application
Mobil Polyrex™ EM	Mobil	-29° C	120° C	Mineral Oil	Polyurea	Blue	Electric motor grease; very good resistance to water/salt water

NOTE: For other grease options consult your Timken sales engineer.

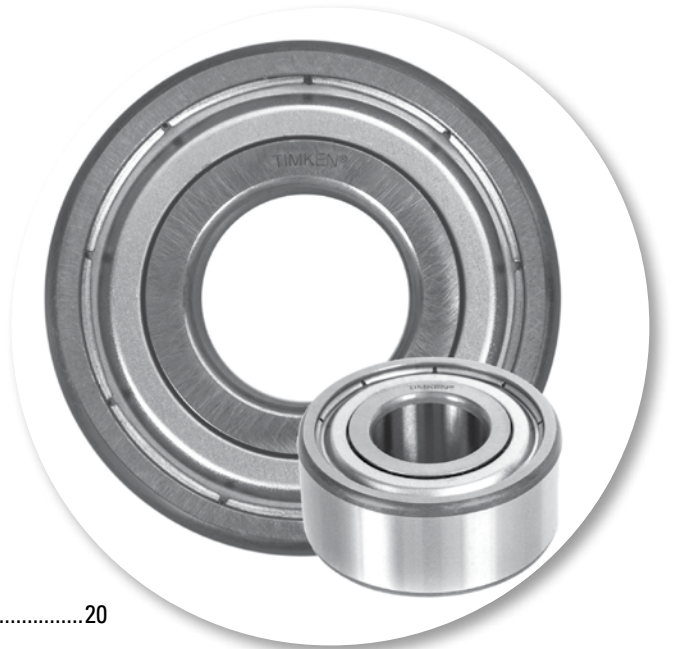

***ANGULAR CONTACT
BALL BEARINGS***

Nomenclatures.....20

Single-Row Angular Contact Ball Bearings22

Double-Row Angular Contact Ball Bearings.....26

NOMENCLATURES

SINGLE ROW

ISO 7000 SERIES

Contact Angle = 40°

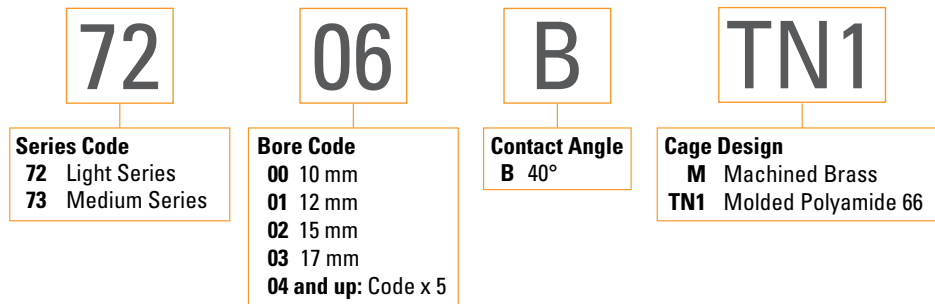

Fig. 15. Single-row standard design angular contact ball bearing nomenclature.

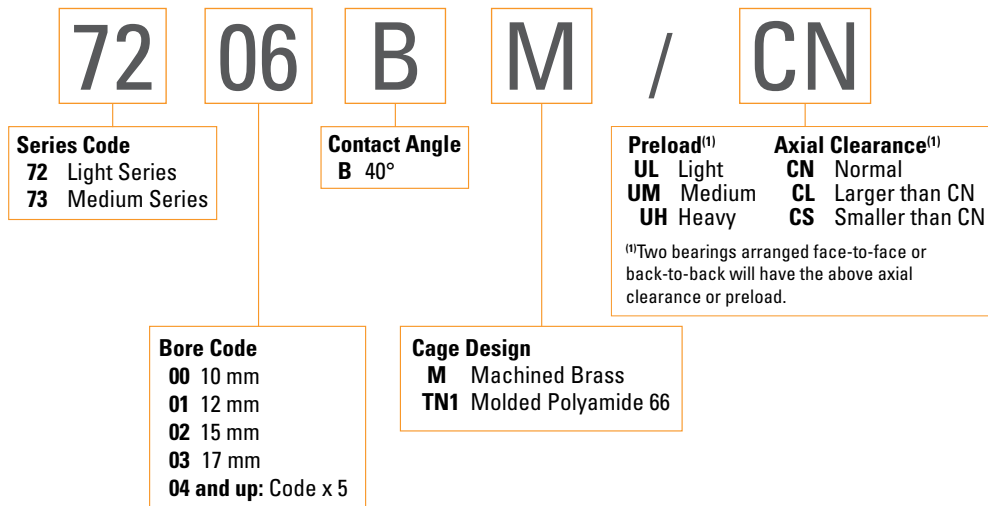

Fig. 16. Single-row universally matched design angular contact ball bearing nomenclature.

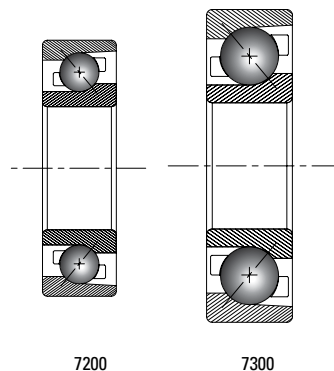

Fig. 17. Single-row angular contact ball bearing series.

NOMENCLATURES

DOUBLE ROW

ISO 3000 SERIES

Contact Angle = 30°

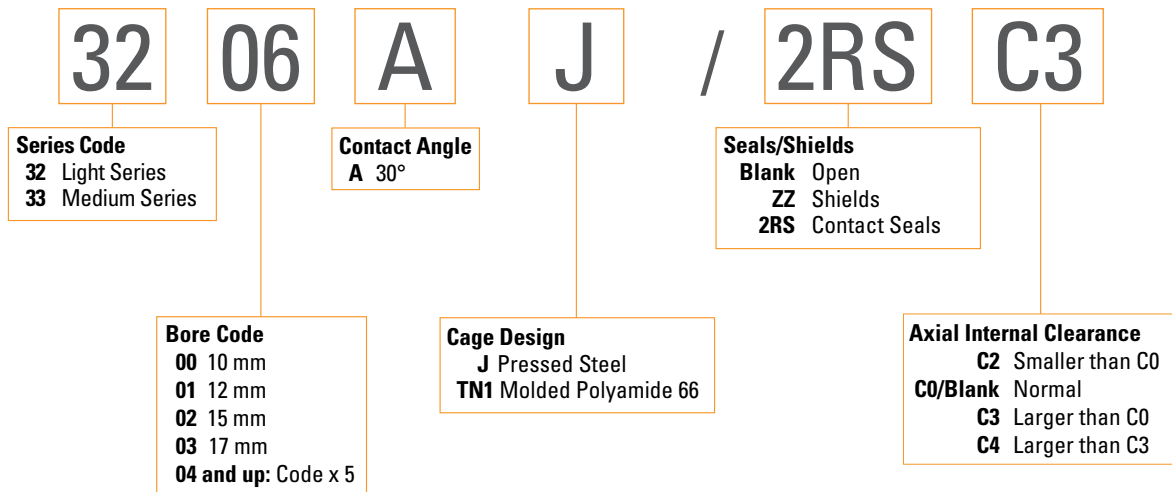

Fig. 18. Double-row design angular contact ball bearing nomenclature.

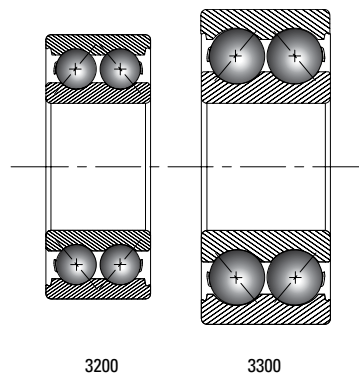
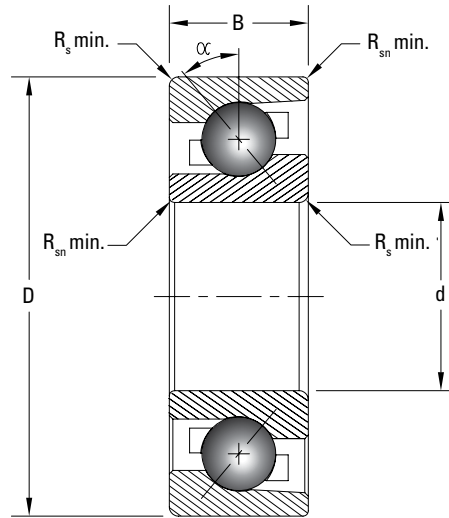

Fig. 19. Double-row angular contact ball bearing series.

SINGLE-ROW ANGULAR CONTACT BALL BEARINGS

7200 - 7300 SERIES



Bearing No.	Boundary Dimensions					Load Ratings	
Description	Bore d	O.D. D	Width B	Radius R _s min	Radius R _{sn} min	Dynamic C _r	Static C _{0r}
	mm	mm	mm	mm	mm	kN	kN
7200 B	10	30	9	0.6	0.3	5.65	2.58
7201 B	12	32	10	0.6	0.3	7.40	3.70
7301 B	12	37	12	1.0	0.6	10.50	5.00
7202 B	15	35	11	0.6	0.3	7.90	4.30
7302 B	15	42	13	1.0	0.6	13.00	6.60
7203 B	17	40	12	0.6	0.3	9.93	5.54
7303 B	17	47	14	1.0	0.6	16.00	8.30
7204 B	20	47	14	1.0	0.6	13.30	7.63
7304 B	20	52	15	1.1	0.6	17.30	9.70
7205 B	25	52	15	1.0	0.6	14.00	8.67
7305 B	25	62	17	1.1	0.6	24.40	14.10
7206 B	30	62	16	1.0	0.6	20.50	13.50
7306 B	30	72	19	1.1	0.6	31.00	19.30
7207 B	35	72	17	1.1	0.6	27.10	18.40
7307 B	35	80	21	1.5	1.0	38.40	24.40
7208 B	40	80	18	1.1	0.6	34.50	23.90
7308 B	40	90	23	1.5	1.0	42.20	27.70
7209 B	45	85	19	1.1	0.6	34.30	24.40
7309 B	45	100	25	1.5	1.0	55.00	36.80
7210 B	50	90	20	1.1	0.6	37.40	28.60
7310 B	50	110	27	2.0	1.0	68.20	47.90
7211 B	55	100	21	1.5	1.0	46.30	36.00
7311 B	55	120	29	2.0	1.0	78.80	56.30
7212 B	60	110	22	1.5	1.0	56.10	44.40
7312 B	60	130	31	2.1	1.1	84.90	60.00

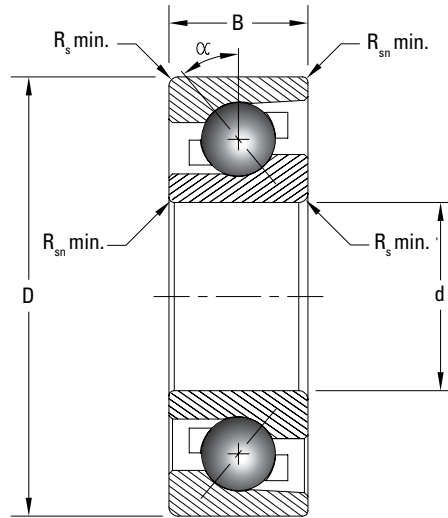

Limiting Speed		Design		Cage		Weight	Recommended Shaft Shoulder Diameter Min.	Recommended Housing Shoulder Diameter Max.
Grease ⁽¹⁾⁽²⁾	Oil ⁽¹⁾⁽²⁾							
RPM	RPM							
24000	32000	•	•		•	0.03	15.0	25.0
21000	28000	•	•		•	0.04	17.0	27.0
19000	26000	•	•		•	0.05	18.0	31.0
18000	25000	•	•		•	0.05	20.0	30.0
17000	22000	•	•		•	0.06	21.0	36.0
17000	22000	•	•	•	•	0.07	22.0	35.0
15000	20000	•	•		•	0.11	23.0	41.0
15000	20000	•	•	•	•	0.10	26.0	41.0
13000	18000	•	•	•	•	0.14	27.0	45.0
12000	16000	•	•	•	•	0.13	31.0	46.0
11000	15000	•	•	•	•	0.23	32.0	55.0
11000	14000	•	•	•	•	0.20	36.0	56.0
9600	13000	•	•	•	•	0.35	37.0	65.0
9300	12000	•	•	•	•	0.29	42.0	65.0
8400	11000	•	•	•	•	0.47	43.5	71.5
8300	11000	•	•	•	•	0.36	47.0	73.0
7400	9900	•	•	•	•	0.64	48.5	81.5
7400	9900	•	•	•	•	0.41	52.0	78.0
6600	8900	•	•	•	•	0.85	53.5	91.5
6700	9000	•	•	•	•	0.47	57.0	83.0
6000	8100	•	•	•	•	1.11	60.0	100.0
6100	8200	•	•	•	•	0.61	63.5	91.5
5500	7300	•	•	•	•	1.42	65.0	110.0
5700	7600	•	•	•	•	0.78	68.5	101.5
5100	6800	•	•	•	•	1.77	72.0	118.0

⁽¹⁾Single-row values for both oil and grease lubrication are for an open bearing configuration.

⁽²⁾Single-row values when mounted in a duplex pair will have a lower limiting speed.

SINGLE-ROW ANGULAR CONTACT BALL BEARINGS

7200 - 7300 SERIES

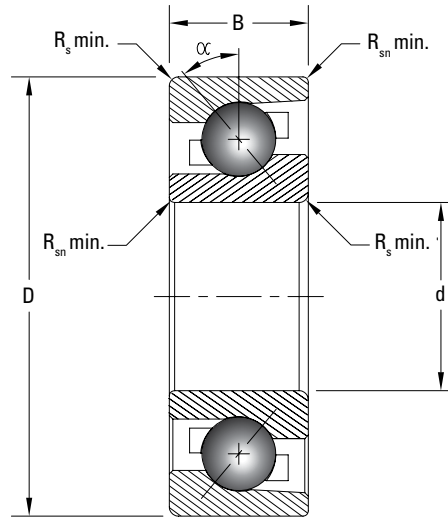

Bearing No.	Boundary Dimensions					Load Ratings	
Description	Bore d	O.D. D	Width B	Radius R _s min	Radius R _{sn} min	Dynamic C _r	Static C _{0r}
	mm	mm	mm	mm	mm	kN	kN
7213 B	65	120	23	1.5	1.0	63.60	52.60
7313 B	65	140	33	2.1	1.1	101.80	75.40
7214 B	70	125	24	1.5	1.0	69.10	57.80
7314 B	70	150	35	2.1	1.1	114.40	86.00
7215 B	75	130	25	1.5	1.0	69.00	58.30
7315 B	75	160	37	2.1	1.1	124.50	97.30
7216 B	80	140	26	2.0	1.0	80.50	69.20
7316 B	80	170	39	2.1	1.1	134.80	109.20
7217 B	85	150	28	2.0	1.0	79.70	70.20
7317 B	85	180	41	3.0	1.1	145.40	122.00
7218 B	90	160	30	2.0	1.0	106.60	93.70
7318 B	90	190	43	3.0	1.1	147.40	124.00
7219 B	95	170	32	2.0	1.1	115.80	100.70
7319 B	95	200	45	3.0	1.1	162.30	141.30
7220 B	100	180	34	2.1	1.1	130.00	114.00
7320 B	100	215	47	3.0	1.1	190.00	178.00
7221 B	105	190	36	2.1	1.1	142.00	129.00
7321 B	105	225	49	3.0	1.1	189.80	180.30
7222 B	110	200	38	2.1	1.1	153.90	144.30
7322 B	110	240	50	3.0	1.1	213.00	206.50
7224 B	120	215	40	2.1	1.1	165.40	161.40
7226 B	130	230	40	3.0	1.1	171.00	174.00

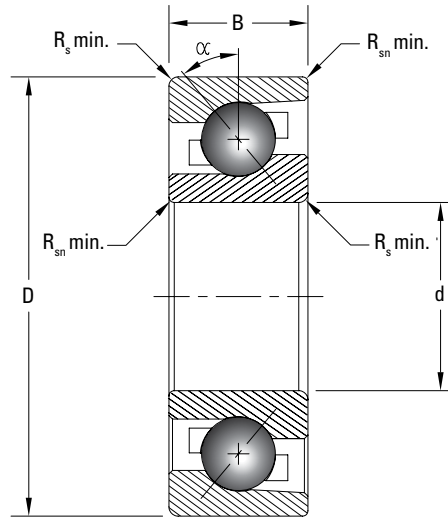

Limiting Speed		Design		Cage		Weight	Recommended Shaft Shoulder Diameter Min.	Recommended Housing Shoulder Diameter Max.
Grease ⁽¹⁾⁽²⁾	Oil ⁽¹⁾⁽²⁾							
RPM	RPM	Standard	Universally Matched	Brass	Polyamide	kg	mm	mm
5200	7000	•	•	•	•	0.98	73.5	111.5
4700	6300	•	•	•	•	2.15	77.0	128.0
4900	6500	•	•	•	•	1.11	78.5	116.5
4400	5800	•	•	•	•	2.61	82.0	138.0
4500	6000	•	•	•	•	1.19	83.5	121.5
4100	5400	•	•	•	•	3.13	87.0	148.0
4300	5700	•	•	•	•	1.42	90.0	130.0
3800	5100		•	•		3.72	92.0	158.0
4000	5300		•	•		2.11	95.0	140.0
3600	4800		•	•		4.95	99.0	166.0
3800	5000		•	•		2.50	100.0	150.0
3400	4500		•	•		5.76	104.0	176.0
3500	4700		•	•		3.03	107.0	159.0
3200	4200		•	•		6.57	109.0	186.0
3400	4500		•	•		3.60	112.0	168.0
3000	4000		•	•		7.32	114.0	201.0
3200	4300		•	•		3.70	117.0	178.0
2900	3800		•	•		8.36	119.0	211.0
3000	4000		•	•		5.12	122.0	188.0
2700	3700		•	•		11.2	124.0	226.0
2800	3700		•	•		6.18	132.0	203.0
2500	3400		•	•		7.15	144.0	216.0

⁽¹⁾Single-row values for both oil and grease lubrication are for an open bearing configuration.

⁽²⁾Single-row values when mounted in a duplex pair will have a lower limiting speed.

DOUBLE-ROW ANGULAR CONTACT BALL BEARINGS

3200 - 3300 SERIES

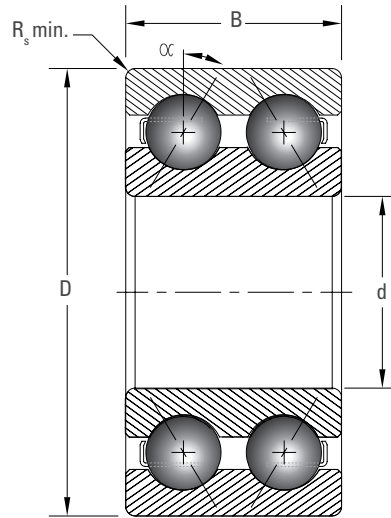

Bearing No.	Boundary Dimensions				Load Ratings	
	Bore d	O.D. D	Width B	Radius R _s min	Dynamic C _r	Static C _{0r}
Description	mm	mm	mm	mm	kN	kN
3201 A	12	32	15.9	0.6	9.40	5.20
3202 A	15	35	15.9	0.6	11.35	6.87
3302 A	15	42	19.0	1.0	14.20	8.70
3203 A	17	40	17.5	0.6	12.75	8.41
3303 A	17	47	22.2	1.0	15.80	10.00
3204 A	20	47	20.6	1.0	15.30	10.40
3304 A	20	52	22.2	1.1	22.60	14.70
3205 A	25	52	20.6	1.0	16.30	12.00
3305 A	25	62	25.4	1.1	28.90	19.40
3206 A	30	62	23.8	1.0	28.60	20.60
3306 A	30	72	30.2	1.1	39.50	29.20
3207 A	35	72	27.0	1.1	30.50	23.70
3307 A	35	80	34.9	1.5	49.50	35.30
3208 A	40	80	30.2	1.1	40.20	32.30
3308 A	40	90	36.5	1.5	60.50	44.20
3209 A	45	85	30.2	1.1	40.00	32.60
3309 A	45	100	39.7	1.5	66.40	49.60
3210 A	50	90	30.2	1.1	43.90	39.90
3310 A	50	110	44.4	2.0	78.90	60.10
3211 A	55	100	33.3	1.5	56.90	47.90
3311 A	55	120	49.2	2.0	92.20	71.00
3212 A	60	110	36.5	1.5	59.90	53.60
3312 A	60	130	54.0	2.1	121.50	95.30
3213 A	65	120	38.1	1.5	73.50	66.60
3313 A	65	140	58.7	2.1	129.60	103.60
3314 A	70	150	63.5	2.1	154.00	125.00

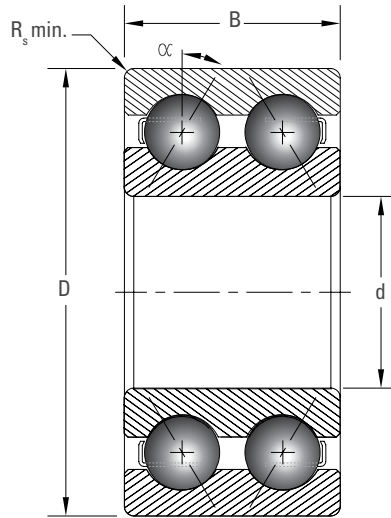

Limiting Speed		Cage		Features		Weight	Recommended Shaft Shoulder Diameter Min.	Recommended Housing Shoulder Diameter Max.
Grease ⁽¹⁾	Oil ⁽²⁾							
RPM	RPM	Polyamide	Steel	ZZ	2RS	kg	mm	mm
13400	17800	•		•	•	0.06	16.4	27.6
11600	15100	•		•	•	0.06	19.4	30.6
9800	13300	•			•	0.13	20.6	36.4
9800	13400	•		•	•	0.10	21.4	35.6
8900	11600	•			•	0.19	22.6	41.4
8900	11600	•	•	•	•	0.17	25.6	41.4
8000	10700	•	•	•	•	0.21	27.0	45.0
7300	9800	•	•	•	•	0.18	31.0	46.0
6700	8900	•	•	•	•	0.19	32.0	55.0
6300	8400	•	•	•	•	0.30	36.0	56.0
5700	7600	•	•	•	•	0.55	37.0	65.0
5500	7400	•	•	•	•	0.39	42.0	65.0
5000	6600	•	•	•	•	0.75	43.5	71.5
4900	6600	•	•	•	•	0.61	47.0	73.0
4400	5900	•	•		•	1.00	48.5	81.5
4400	5900	•	•	•	•	0.71	52.0	78.0
4000	5300	•	•			1.33	53.5	91.5
4000	5300	•	•	•	•	0.70	57.0	83.0
3600	4800	•	•			1.74	60.0	100.0
3600	4900		•		•	0.95	63.5	91.5
3300	4400		•			2.42	65.0	110.0
3400	4500		•			1.38	68.5	101.5
3000	4000		•		•	2.91	72.0	118.0
3100	4200		•			1.66	73.5	111.5
2800	3700		•			3.90	77.0	128.0
2600	3500		•			3.90	82.0	138.0

⁽¹⁾Double-row values for grease lubrication are for a sealed bearing configuration.

⁽²⁾Double-row values for oil lubrication are for an open bearing configuration.



To view more Timken catalogs, go to www.timken.com/catalogs for interactive versions, or to download a catalog app for your smart phone or mobile device scan the QR code or go to www.timkencatalogs.com.

07-19 Order No. 11193 | Timken® is a registered trademark of The Timken Company. | © 2019 The Timken Company
All other trademarks are the property of their respective owners.

TIMKEN

The Timken team applies their know-how to improve the reliability and performance of machinery in diverse markets worldwide. The company designs, makes and markets bearings, gear drives, automated lubrication systems, belts, brakes, clutches, chain, couplings, linear motion products and related power transmission rebuild and repair services.

Stronger. By Design.

www.timken.com