

**DIMENSIONI D'INGOMBRO B5** IT

**OVERALL DIMENSIONS B5** EN

**GESAMTMESSUNGEN B5** DE

**DIMENSIONS D'ENCOMBREMENT B5** FR

**DIMENSIONES DE LA MÁQUINA B5** ES

**DIMENSÕES DE ESTORVO B5** PT

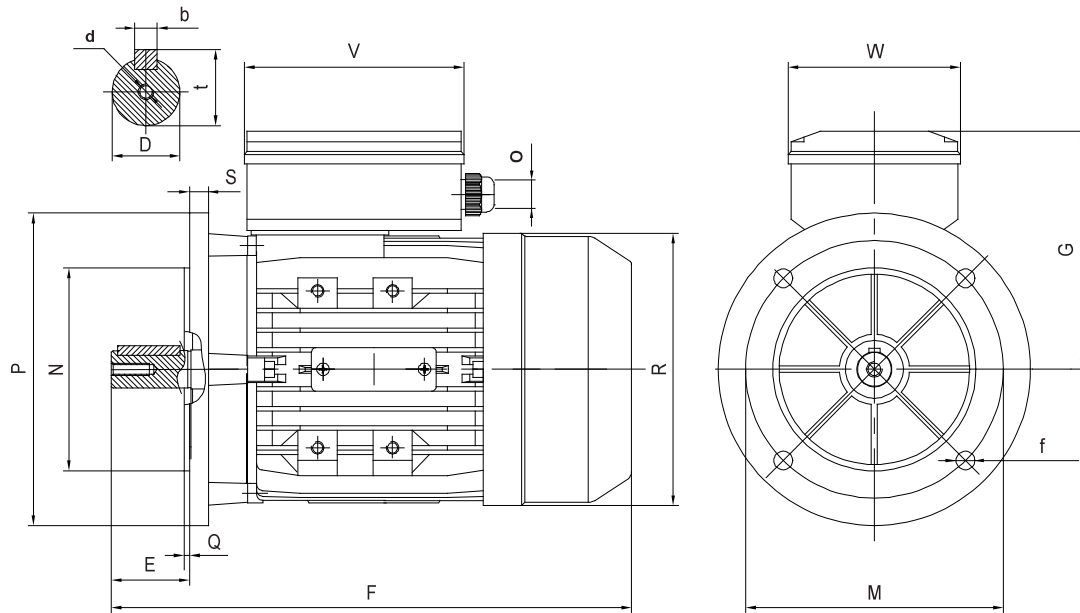

GRANDEZZA SIZE GRÖÖE Taille TAMAÑO TAMANHO	N. Poli No.Poles Polenanzahl N. Póles N.º polos N.º Pólos	QUOTA / DIMENSION / ABMESSUNG / NIVEAU / COTA / QUOTA																	
		D	d	E	F	f	G	M	N	O	P	Q	R	S	V	W	b	t	
56	2-4-6	9j6	-	20	194	7	95	101.5	80j6	M16	120	2.5	114	9	73	73	3	10.2	
63		11j6	M4x0.7	23	220	10	100	115	95j6	M16	140	3	128	9	80	80	4	12.5	
71		14j6	M5x0.8	30	255	10	105	130	110j6	M20	160	3	140	9	80	80	5	16	
80		19j6	M6x1	40	292	12	135	165	130j6	M20	200	3.5	160	12	105	105	6	21.5	
90S		24j6	M8x1.25	50	337	12	137	165	130j6	M20	200	3.5	175	12	105	105	8	27	
90L		28j6	M10x1.5	60	386	15	147	215	180j6	M20 + M20	250	4	200	15	105	105	8	31	
100L		28j6	M10x1.5	60	393	14	165	215	180j6	M25 + M25	250	4	228	13	115	122	8	31	
132S		38k6	M12x1.75	80	493	15	185	265	230j6	M25 + M25	300	4	258	14	115	122	10	41	
132M		42	M16x36	110	608	19	243	300	250	M32x1.5+ M25x1.5	350	5	312	15				12	45
160M		652																	
160L		48	M16x36	110	720	19	265	300	250	M32x1.5+ M25x1.5	350	5	355	15				14	51,5
180M		770	265																
180L		55	M20x42	110	780	19	305	350	300	2-M36x2	400	5	397	17				16	59
200L																			

dimensioni in mm  
dimensions en mm

overall dimensions in mm  
dimensiones en mm

Abmessungen in mm  
dimensões em mm