



Technical data

722513 DA

Flanged housings 722500

Flanged housing for bearings on adapter sleeve, made of grey cast, for grease lubrication

VISUAL (S)

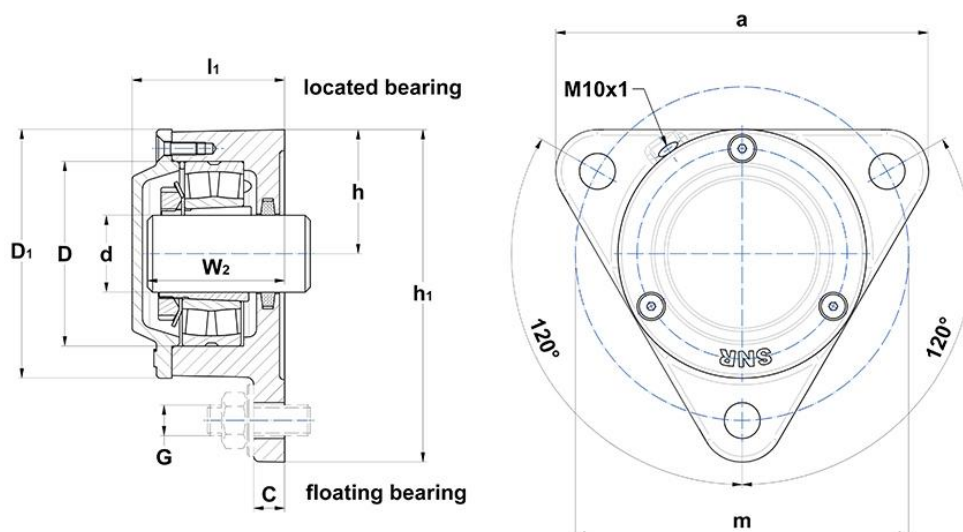

PRODUCT DIMENSIONS

Shaft diameter (d)	60 mm
outer diameter cover (D1)	152 mm
Housing length (a)	225 mm
Housing foot height (c)	15 mm
Bearing center height (h)	78 mm
Housing height (h1)	203 mm
Housing width over covers (l1)	80 mm
Mounting hole (or punches) distance (length) (m)	190 mm

PRODUCT DIMENSIONS

Mounting hole diameter (N)	14 mm
Bearing seat diameter (D)	120 mm
base to shaft end distance (W2)	69 mm
Mass	5,9 kg
New Material of Housing	grey cast
Brand	SNR

BOLTS

Fixing bolts (G)	M12
Recommended torque fixing bolts	65.0 N-m
Cover bolts	M6x20
Recommended torque cover bolts	7.0 N-m

ASSOCIATED COMPONENTS - OPTION 1

Bearing	1213 K C3
Adapter sleeve	H213
Fixing ring (1x)	FR120x10x4

ASSOCIATED COMPONENTS - OPTION 2

Bearing	2213 K C3
Adapter sleeve	H313
Fixing ring (1x)	FE120x100x2

ASSOCIATED COMPONENTS - GENERAL

feltstrip	FS 8 x 6,5 x 240
------------------	------------------

ASSOCIATED COMPONENTS - OPTION 3

Bearing	22213 K
----------------	---------

ASSOCIATED COMPONENTS - OPTION 3

Adapter sleeve	H313
Fixing ring (1x)	FE120x100x2