

FAG

**B71928-E-T-P4S-UL**

Spindle bearing

Schaeffler ID:  
0191552800000

Spindle bearing B719...-E-T-P4S, with steel balls

## Technical information

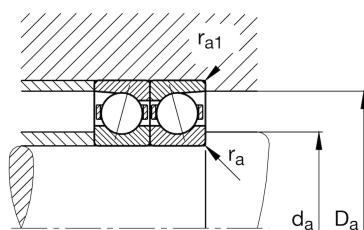
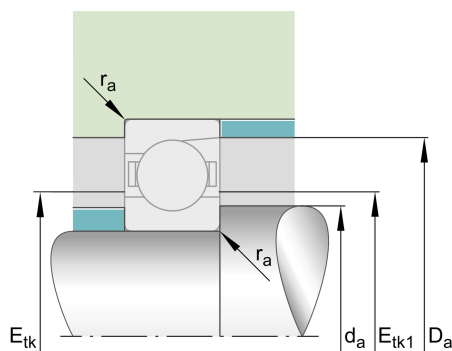
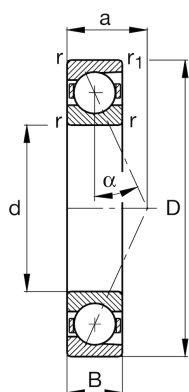
**Main Dimensions & Performance Data**

d	140 mm	Bore diameter
D	190 mm	Outside diameter
B	24 mm	Width
$C_r$	89.000 N	Basic dynamic load rating, radial
$C_{0r}$	73.000 N	Basic static load rating, radial
$C_{ur}$	6.000 N	Fatigue load limit, radial
$n_{G\text{ Grease}}$	6.000 1/min	Limiting speed for grease lubrication
$n_{G\text{ Oil}}$	9.500 1/min	Limiting speed for oil lubrication
	1,592 kg	Weight

**Dimensions**

$r_{\min}$	1,5 mm	Minimum chamfer dimension
$r_{1\min}$	1,5 mm	Minimum chamfer dimension
$\alpha$	25 °	Contact angle

**Mounting dimensions**

$d_a$	149 mm	Diameter shaft shoulder
$d_a$	h12	Diameter shaft shoulder clearance
$D_a$	181 mm	Shoulder diameter outer ring
$D_a$	H12	Shoulder diameter outer ring clearance
$r_{a\max}$	0,6 mm	Maximum recess radius
$r_{a1\max}$	0,6 mm	Maximum recess radius
$E_{tk\min}$	155,5 mm	Minimum diameter injection pitch
$E_{tk\max}$	160,6 mm	Maximum diameter injection pitch
$E_{tk1\min}$	155,5 mm	Minimum diameter injection pitch
$E_{tk1\max}$	160,6 mm	Maximum diameter injection pitch
a	50,5 mm	Distance between the apices of the pressure cones

**Additional information**

$F_{VL}$	736 N	Preload force light
$F_{VM}$	2.564 N	Preload force medium
$F_{VH}$	5.373 N	Preload force heavy
$K_{aEL}$	2.136 N	Lift-off force light
$K_{aEM}$	7.663 N	Lift-off force medium
$K_{aEH}$	16.542 N	Lift-off force heavy
$c_{aL}$	292 N/ $\mu$ m	Axial rigidity light
$c_{aM}$	466 N/ $\mu$ m	Axial rigidity medium
$c_{aH}$	628 N/ $\mu$ m	Axial rigidity heavy